

# *A TUBE PRIMER FOR GUITAR AND BASS PLAYERS*

*WHAT TUBES SHOULD I USE IN MY GUITAR OR BASS AMPLIFIER?*

## *Guitar Amplifier Blueprinting* *Part 2 of 2*

Myles S. Rose

[www.guitaramplifierblueprinting.com](http://www.guitaramplifierblueprinting.com)

THIS DOCUMENT WAS FORMATTED FOR “LANDSCAPE” RATHER THAN “PORTRAIT” AS IT WAS INTENDED TO BE ABLE TO BE VIEWED ON A COMPUTER. ON COMPUTERS, MOST SCREENS ARE WIDER THAN HIGHER. THERE ARE ALSO NUMEROUS LINKS WITH ADDITIONAL INFORMATION PROVIDED. THIS WILL PRINT OUT NICELY USING ACROBAT.

What are the differences between tubes?

What is a phase inverter? What about a matched phase inverter?

What is matching? Static versus dynamic matching?

Aren't all tubes really the same?

Is 100 watts twice as loud as 50 watts? How much power do I need?

These questions ***and more*** are covered in this document

<b>POINT TO POINT VERSUS PCB CONSTRUCTION BY ANDY MARSHALL OF THD ELECTRONICS .....</b>	<b>5</b>
<b>TUBES IN DETAIL – CONSTRUCTION, OPERATION, AND MORE .....</b>	<b>8</b>
<b>A. CATHODE .....</b>	<b>11</b>
<b>B. PLATE (ANODE) .....</b>	<b>12</b>
<b>C. CONTROL GRID .....</b>	<b>13</b>
<b>D.SCREEN GRID--THE TETRODE .....</b>	<b>15</b>
<b>E. OTHER GRIDS--THE PENTODE .....</b>	<b>16</b>
<b>F. AUDIO BEAM TETRODE .....</b>	<b>17</b>
<b>G. THE HEATER INSIDE THE CATHODE .....</b>	<b>18</b>
<b>H.THE GETTER .....</b>	<b>18</b>
<b>I. ASSEMBLING THE TUBE .....</b>	<b>19</b>
<b>WHY ARE TUBES STILL USED? .....</b>	<b>25</b>
<b>A. HIGH-POWER RF APPLICATIONS .....</b>	<b>25</b>
<b>B. GUITAR AMPS .....</b>	<b>25</b>
<b>C. PROFESSIONAL AUDIO .....</b>	<b>26</b>
<b>D. HIGH-END AUDIO .....</b>	<b>26</b>
<b>USING TUBES .....</b>	<b>26</b>
<b>A. BIAS.....</b>	<b>26</b>
<b>B. WHEN SHOULD I REPLACE THE TUBES? .....</b>	<b>26</b>

<b>C. BLUE GLOW -- WHAT CAUSES IT?.....</b>	<b>27</b>
<b>D. WHAT IS CLASS A, B, AB, ULTRALINEAR, ETC.? .....</b>	<b>28</b>
<b>TUBES VS TRANSISTORS: IS THERE AN AUDIBLE DIFFERENCE? .....</b>	<b>31</b>
<b>INTRODUCTION: .....</b>	<b>31</b>
<b>PSYCHOACOUSTICS .....</b>	<b>31</b>
<b>MICROPHONE OUTPUT LEVELS .....</b>	<b>32</b>
<b>DISTORTION CHARACTERISTICS OF PREAMPLIFIERS .....</b>	<b>36</b>
<b>1) TUBE CHARACTERISTICS .....</b>	<b>39</b>
<b>SIGNIFICANCE OF MUSICAL HARMONICS .....</b>	<b>47</b>
<b>RELATIONSHIP OF FACTORS AND FINDINGS.....</b>	<b>48</b>
<b>TUBE VARIABILITY – THE MOST VARIABLE COMPONENT IN YOUR AMPLIFIER.....</b>	<b>50</b>
<b>MATCHED PHASE INVERTERS AND DRIVERS .....</b>	<b>52</b>
<b>WHY DO TWO MARSHALLS OR TWO FENDERS, OF THE SAME MODEL, AND EVEN YEAR, SOUND DIFFERENT – AND MORE ON MATCHING OF PHASE INVERTERS, BALANCED OUTPUT SECTIONS, GLOBAL FEEDBACK, AND MORE .....</b>	<b>54</b>
<b>ON THE SAME SUBJECT – WHY DO MARSHALL AND FENDER AMPS SOUND DIFFERENT?.....</b>	<b>56</b>
<b>PREAMP TUBES - GAIN / OUTPUT AND MATCHING – MORE INFORMATION .....</b>	<b>60</b>
<b>PART 2 - GAIN VERSUS OUTPUT IN PREAMP TUBES .....</b>	<b>61</b>
<b>POWER / WATTAGE – HOW MUCH DO YOU REALLY NEED?.....</b>	<b>62</b>
<b>FENDER BLACKFACE TUBE USE AND APPLICATION .....</b>	<b>65</b>
<b>THOUGHTS ON 12AX7 TYPE TUBES BY MARK BAIER.....</b>	<b>66</b>
<b>BLUEPRINTING AMPLIFIERS – WHAT IS “BLUEPRINTING” ? .....</b>	<b>69</b>

<b>WHICH AMP IS BETTER ?.....</b>	<b>72</b>
<b>NOS TUBES – THE HYPE, MYTH, AND REALITY .....</b>	<b>73</b>
<b>THE REALITY OF NOS .....</b>	<b>73</b>
<b>THERE ARE SOME POINTS OF LIGHT ON THE HORIZON THANKFULLY IN REGARD TO NEW TUBES .....</b>	<b>75</b>
<b>MATCHING IN MORE DETAIL – STATIC VERSUS DYNAMIC MATCHING .....</b>	<b>77</b>
<b>POINT TO POINT AMPS - SOME MYTHS AND ALSO WHY SOME TECHS PREFER THEM .....</b>	<b>80</b>
<b>RECORDING YOUR GUITAR.....</b>	<b>84</b>
<b>GUITAR SPEAKERS .....</b>	<b>85</b>
<b>TUBE TEST RESULTS DECEMBER 2003 AND BEYOND .....</b>	<b>86</b>
<b>GROOVE TUBES NVM MULLARD 12AX7 SERIES 1 – ORIGINAL SPEC .....</b>	<b>86</b>
<b>GROOVE TUBES NVM MULLARD 12AX7 SERIES 3 – “SUPER MULLARD” .....</b>	<b>87</b>
<b>12AX7WC SOVTEK – 0310 DATECODE.....</b>	<b>88</b>
<b>12AX7WC SOVTEK – 0311 DATECODE – PRODUCTION TEST OF SOVTEK BULK DELIVERY.....</b>	<b>89</b>
<b>SOME POSTS FROM MUSIC FORUMS .....</b>	<b>90</b>

## **Point to Point versus PCB construction by Andy Marshall of THD Electronics**

**THE FOLLOWING WAS WRITTEN BY ANDY MARSHALL, OWNER AND FOUNDER OF THD ELECTRONICS. THD OFFERS AMPS SUCH AS THE UNIVALVE AND BIVALVE, TRANSFORMERS, REACTIVE RECTIFIERS, THE WELL KNOWN THD HOT PLATE, YELLOW JACKETS, AND MORE. A TWEED BASSMAN RECREATION THAT ANDY MARSHALL OFFERED IN THE PAST, HAS THE DISTINCTION OF A COMMENT FROM ASPEN PITTMAN – THAT IT WAS THE FINEST BASSMAN THAT HE HAD EVER SEEN OR HEARD AT THAT TIME.**

**MORE CAN BE SEEN ON THD ELECTRONICS BY FOLLOWING THE LINK HERE – [WWW.THDELECTRONICS.COM](http://WWW.THDELECTRONICS.COM)**

Not all manufacturers choose to use PC boards just to save money. We use them for consistency more than for price, but making a somewhat affordable amplifier is a nice benefit. I don't think that someone should have to be a lawyer or Microsoft Millionaire to be able to afford a new amplifier that is hand-built, reliable and sounds and feels good to play.

If a PC board is designed correctly and the correct components are used, the amplifier production should be absolutely consistent from one unit to the next. No re-routing of traces should ever be necessary to make an amp function or sound right. If you find it necessary to change and re-rout wires in your amps, then you are not in production, but are just making a series of unstable prototypes. Treble reduction to the point where it reduces the clarity of the amplifier is not an acceptable stabilizing technique for either a PTP or PCB amplifier.

Recently, we got a call from a tech complimenting us on our old Plexi model amplifier (that we built between 1990 and 1995), but he said that it was just a little bit "stiff in the high-end" compared to a real Marshall Plexi. To back up his point, he told us that he had a real Marshall Plexi on the bench next to ours and was comparing the two side by side. What he did not seem to realize was that no two Marshall Plexis sound the same. They were terribly inconsistent with their component sources and values, not to mention the inconsistencies in wire routing.

Taking a point to point or a turret-board amplifier, if one moves the wires around, the entire sound and character of the amplifier can change, often dramatically. This is a well-recognized phenomenon.

If you understand these interactions well, you can design a PC board to sound and feel any way you want it to. Furthermore, every one will sound the same. How many times have you plugged into an old Marshall-50 watt head, only to be terribly disappointed by the sound and feel of the amplifier? While this may be caused by poor tubes, at least in part, inconsistencies in the internal layout of the amplifier often play a significant role.

If you understand how one component affects the component next to it and how one trace affects the trace next to it, then you should be

able lay out a circuit board correctly the first time, not by building 10 and picking the best one. Mind you, it takes many years of experience to develop the sort of understanding of the capacitive and inductive interrelations involved. In the old days, I did this for a living for other companies, designing circuit boards for the audio sections of amplifiers, mixing consoles, signal processing equipment, etc... While I am under confidentiality agreements with almost all of my former clients, I can tell you that there is hardly a professional recording studio in the US or Europe that does not have some audio circuit board with my layout in some piece of equipment.

After a few hundred such projects, one develops an intricate understanding of how traces and components interact

A number of years ago, Guitar Player magazine did a review of one of our amplifiers. They stated that they, as a general rule, do not care for circuit board amplifiers, but also said that I had addressed every one of their concerns, and that they had nothing bad to say regarding our use of circuit boards. It felt good to see someone start to understand what it is that we do and why.

Certain components throw a rather large field. Others do not. Some components are very susceptible to the fields from other components, while some are not. Components can affect the signal passing through traces, and traces can affect the signal passing through components. It ends up being an enormous network of positive and negative feedback between components within each other's sway. This is why the distance between specific components on the board and the physical orientation of the components relative to one another (rotational orientation, as well as lateral placement) cannot be ignored. Furthermore, which traces are parallel to one another and at what distance, which traces are perpendicular to one another and that what distance, and the amount of ground plane in-between them can seriously affect the overall sound and feel of the finished amplifier.

Most people design circuit boards either haphazardly or for the greatest parts density/easiest and least expensive manufacture. Neither of these methods belongs in a high-end amplifier, and such approaches give PC Board designs a bad name.

If you know what you are doing, a thicker board is better than a thinner board (ours are .093" or 3/32", most are .062" or 1/16?) and that thick copper is a good idea (ours is 4 oz, most use 1/2 oz or 1 oz). One of the greatest problems facing most circuit board amplifiers is board flex. Board flex creates metal fatigue in the copper. As the copper cannot really "break", it just crystallizes and makes tons of noise. This is much worse in combo amps, of course. We go to the trouble to support our boards ever few inches. Our design standard is that 100 pounds of force on a 1/4" diameter probe should not be able to flex the board more than 20 thousandths of an inch at any point on the board. All of our amps designs must pass this test. For comparison, most Marshall and Fender circuit boards would break under such force, and would flex more than 3/8 of an inch just before breaking.

Through-plated holes are an absolute must, with solder pads on both sides. This makes it much harder for a repairman to inadvertently lift a pad or a trace by overheating or from poor technique. The way that we have addressed this is to start with boards that are clad with 2 oz copper, and in the through-hole plating process we add another 2 ounces. This leaves us with traces and ground planes of 4 ounces, and through plated holes with 2 oz copper in the holes themselves. I have seen some other people start with 3 oz copper, plating on an additional 1 oz, and I have not like the results I have seen. The through-holes pull out too easily.

Contrary to popular belief, "Orange Drop" film capacitors are far from great. They are OK for certain position in certain circuits, but their consistency from one to the next is atrocious. Maybe this is part of why so many people who use them in PTP amps find the need to make

wire adjustments. This is a big part of what I mean by using the right components.

As for PCB solder joints becoming problematic with time, this is no more a problem than on PTP. A good solder joint with absolute minimum stress on it (using the right component with the right lead length and the right mounting technique) will yield the longest and most consistent life. Assuming that the flow-solder machine is correctly set up, the right solder, right flux, right solder temperature, right flux temperature, right pre-heat, right cooling, etc.? are done, a flow-soldered board will last longer and have higher quality solder joints than a hand-soldered board. If you doubt this, ask yourself the following questions: How do you decide what solder to use? Do you choose SN60, SN63, SN96, Savebit or some other? How do you decide what flux to use in your solder and how much? How do you decide what temperature to set your iron at? It all makes a HUGE difference in the quality and consistency of your solder joints. If you cannot answer all of these questions, then you cannot even have a clue about the long-term consistency and life expectancy of your products. This, along with countless other points, is part of what separates the hobbyist from the professional.

In a PTP amp, the entire surface of the solder joint is exposed to air, and thus, to corrosion. In a through-plated PCB amp, only the top and bottom surfaces of the solder joint are exposed to corrosion, not the majority of the joint, which is within the through-hole, which is where most of the contact is made.

We use only FAA-approved aircraft assemblers in every stage of our manufacturing. They have to understand all of these points completely. The FAA is even more stringent than the military. Also, the aircraft industry is just about the only industry left that uses PCBs for the electronic components wired to chassis-mounted electro-mechanical components like the controls and connectors. They do this because countless FAA tests have shown that devices built this way last longer and are more reliable and consistent than any other method, even taking cost out of the picture entirely. This is, of course, why we use the exact same methods.

In closing, I absolutely believe that circuit boards, when they are well-designed and laid out, are in all ways superior to other manufacturing techniques when one is building amplifiers in quantities. If I did not believe this firmly, I would not be doing it. This said, I think it is a terribly expensive and cumbersome method for hobbyists to attempt. If you don't have a great deal of experience under your belt designing circuit boards, you won't like the results. Point to point and turret-board techniques offer the hobbyist and the small-scale amp shop the opportunity to easily tweak their designs, as is so often necessary. So, unless you're going to be building 50 amps a month or more, it is probably best to stay away from circuit boards.



## TUBES in detail – construction, operation, and more

(This is a document that was produced by Svetlana Electron Devices)

### The BASICS

Back in 1904, British scientist John Ambrose Fleming first showed his device to convert an alternating current signal into direct current. The "Fleming diode" was based on an effect that Thomas Edison had first discovered in 1880, and had not put to useful work at the time. This diode essentially consisted of an incandescent light bulb with an extra electrode inside. When the bulb's filament is heated white-hot, electrons are boiled off its surface and into the vacuum inside the bulb. If the extra electrode (also called an "plate" or "anode") is made more positive than the hot filament, a direct current flows through the vacuum. And since the extra electrode is cold and the filament is hot, this current can only flow from the filament to the electrode, not the other way. So, AC signals can be converted into DC. Fleming's diode was first used as a sensitive detector of the weak signals produced by the new wireless telegraph. Later (and to this day), the diode vacuum tube was used to convert AC into DC in power supplies for electronic equipment.



Many other inventors tried to improve the Fleming diode, most without success. The only one who succeeded was New York inventor Lee de Forest. In 1907 he patented a bulb with the same contents as the Fleming diode, except for an added electrode. This "grid" was a bent wire between the plate and filament. de Forest discovered that if he applied the signal from the wireless-telegraph antenna to the grid instead of the filament, he could obtain a much more sensitive detector of the signal. In fact, the grid was changing ("modulating") the current flowing from the filament to the plate. This device, the Audion, was the first successful electronic amplifier. It was the genesis of today's huge electronics industry.

Between 1907 and the 1960s, a staggering array of different tube families was developed, most derived from de Forest's invention. With a very few exceptions, most of the tube types in use today were developed in the 1950s or 1960s. One obvious exception is the 300B triode, which was first introduced by Western Electric in 1935. Svetlana's SV300B version, plus many other brands, continue to be very popular with audiophiles around the world. Various tubes were developed for radio, television, RF power, radar, computers, and specialized



applications. The vast majority of these tubes have been replaced by semiconductors, leaving only a few types in regular manufacture and use. Before we discuss these remaining applications, let's talk about the structure of modern tubes.

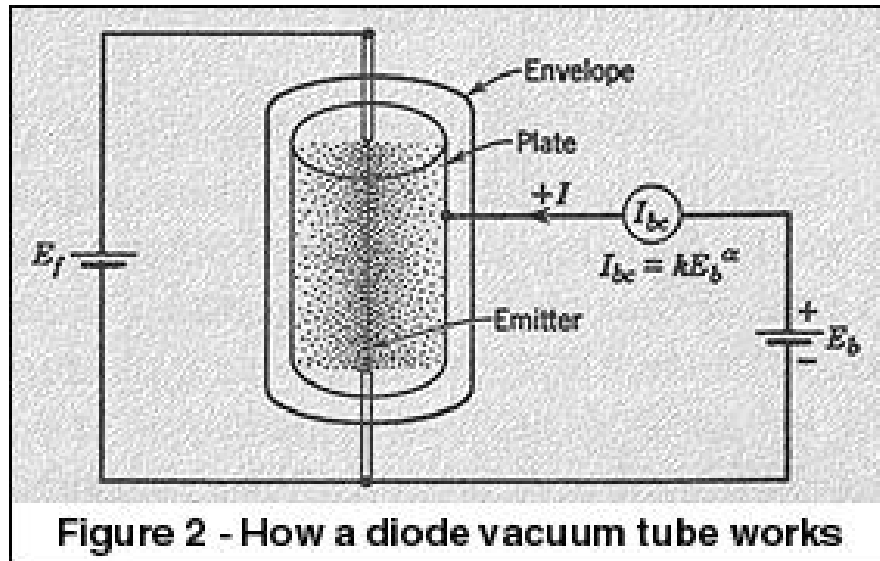

## INSIDE A TUBE

## Inside a miniature tube (this is a pentode)

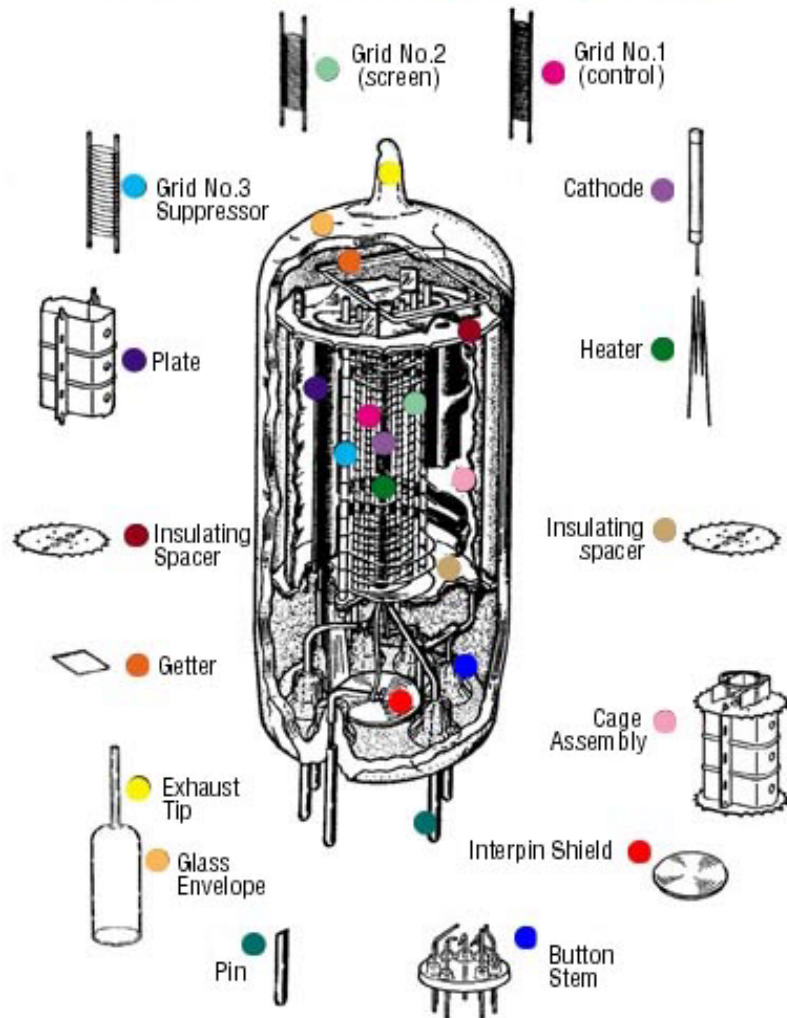

All modern vacuum tubes are based on the concept of the Audion--a heated "cathode" boils off electrons into a vacuum; they pass through a grid (or many grids), which control the electron current; the electrons then strike the anode (plate) and are absorbed. By designing the cathode, grid(s) and plate properly, the tube will make a small AC signal voltage into a larger AC voltage, thus amplifying it. (By

comparison, today's transistor makes use of electric fields in a crystal which has been specially processed--a much less obvious kind of amplifier, though much more important in today's world.)

(Inside a miniature tube, above) shows a typical modern vacuum tube. It is a glass bulb with wires passing through its bottom, and connecting to the various electrodes inside. Before the bulb is sealed, a powerful vacuum pump sucks all the air and gases out. This requires special pumps which can make very "hard" vacuums. To make a good tube, the pump must make a vacuum with no more than a millionth of the air pressure at sea level (one microTorr, in official technical jargon). The "harder" the vacuum, the better the tube will work and the longer it will last. Making an extremely hard vacuum in a tube is a lengthy process, so most modern tubes compromise at a level of vacuum that is adequate for the tube's application.

First, let's talk about the parts of the tube.....

## **A. Cathode**

Today, nearly all tubes use one of two different kinds of cathode to generate electrons.

1) The thoriated filament: it is just a tungsten filament, much like that in a light bulb, except that a tiny amount of the rare metal THORIUM was added to the tungsten. When the filament is heated white-hot (about 2400 degrees Celsius), the thorium moves to the outer surface of it and emits electrons. The filament with thorium is a much better maker of electrons than the plain tungsten filament by itself. Nearly all big power tubes used in radio transmitters use thoriated filaments, as do some glass tubes used in hi-fi amps. The thoriated filament can last a VERY long time, and is very resistant to high voltages.

2) The other kind of cathode is the oxide-coated cathode or filament. This can be either just a filament coated with a mixture of barium and strontium oxides and other substances, or it can be an "indirectly heated" cathode, which is just a nickel tube with a coating of these same oxides on its outer surface and a heating filament inside. The cathode (and oxide coating) is heated orange-hot, not as hot as the thoriated filament--about 1000 degrees Celsius. These oxides are even better at making electrons than the thoriated filament. Because the oxide cathode is so efficient, it is used in nearly all smaller glass tubes. It can be damaged by very high voltages and bombardment by stray oxygen ions in the tube, however, so it is rarely used in really big power tubes.

3) Lifetime of cathodes: The lifetime of a tube is determined by the lifetime of its cathode emission. And the life of the of a cathode is dependent on the cathode temperature, the degree of vacuum in the tube, and purity of the materials in the cathode.

- Tube life is sharply dependent on temperature, which means that it is dependent on filament or heater operating voltage. Operate the heater/filament too hot, and the tube will give a shortened life. Operate it too cool and life may be shortened (especially in thoriated filaments, which depend on replenishment of thorium by diffusion from within the filament wire). A few researchers have observed that the lifetime of an oxide-cathode tube can be greatly increased by operating its heater at 20% below the rated voltage. This USUALLY has very little effect on the cathode's electron emission, and might be worth experimenting with if the user wishes to increase the lifetime of a small-signal tube. (Low heater voltage is NOT recommended for power tubes, as the tube may not give

the rated power output.) Operating the heater at a very low voltage has been observed to linearize some tube types-- we have not been able to verify this, so it may be another worthy experiment for an OEM or sophisticated experimenter. The average end-user is advised to use the rated heater or filament voltage--experimentation is not recommended unless the user is an experienced technician.

- Oxide cathodes tend to give shorter lifetimes than thoriated filaments. Purity of materials is a big issue in making long-lived oxide cathodes--some impurities, such as silicates in the nickel tube, will cause the cathode to lose emission prematurely and "wear out". Low-cost tubes of inferior quality often wear out faster than better-quality tubes of the same type, due to impure cathodes.
- Small-signal tubes almost always use oxide cathodes. Good-quality tubes of this type, if operated well within their ratings and at the correct heater voltage, can last 100,000 hours or more.
- The world record for lifetime of a power tube is held by a large transmitting tetrode with a thoriated filament. It was in service in a Los Angeles radio station's transmitter for 10 years, for a total of more than 80,000 hours. When finally taken out of service, it was still functioning adequately. (The station saved it as a spare.) By comparison, a typical oxide-cathode glass power tube, such as an EL34, will last about 1500-2000 hours; and a tube with an oxide-coated filament, such as an SV300B, will last about 4000-10,000 hours. This is dependent on all the factors listed above, so different customers will observe different lifetimes.

## **B. Plate (anode)**

The plate, or anode, is the electrode that the output signal appears on. Because the plate has to accept the electron flow, it can get hot. Especially in power tubes. So it is specially designed to cool itself off, either by radiating heat through the glass envelope (if it's a glass tube), or by forced-air or liquid cooling (in bigger metal-ceramic tubes). Some tubes use a plate made of graphite, because it tolerates high temperatures and because it emits very few secondary electrons, which can overheat the tube's grid and cause failure. See "H--the getter" below for more about the graphite plate.

## C. Control Grid

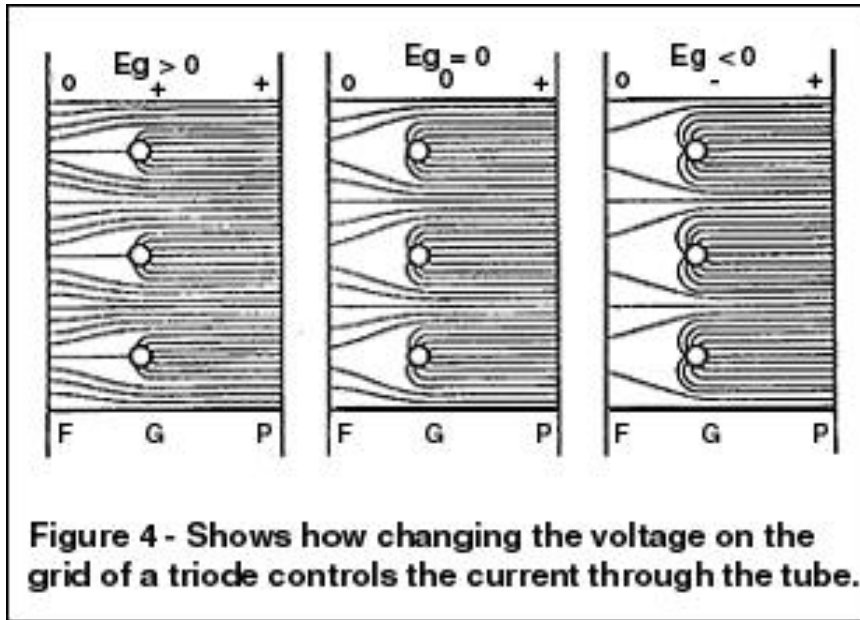

In nearly all glass audio tubes, the control grid is a piece of plated wire, wound around two soft-metal posts. In small tubes the plating is usually gold, and there are two posts made of soft copper. Grids in big power tubes have to tolerate a lot of heat, so they are often made of tungsten or molybdenum wire welded into a basket form. Some large power tubes use basket-shaped grids made of graphite as in the figure below:

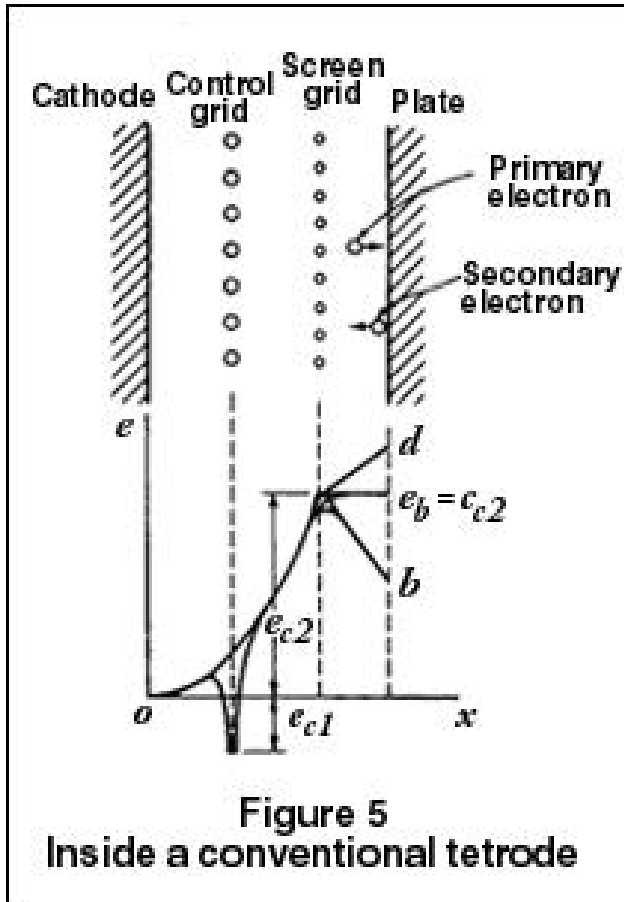

Inside any modern amplifying tube, one of the things to avoid is called secondary emission. This is caused by electrons striking a smooth metal surface. If many secondary electrons come out of the grid, it will lose control of the electron stream, so that the current "runs away", and the tube destroys itself. So, the grid is often plated with a metal that is less prone to secondary emission, such as gold. Special surface finishing is also used to help prevent secondary emission.

A tube with only one grid is a TRIODE. The most widely used small triode, the 12AX7, is a dual triode which has become the standard small-signal amplifier in guitar amps. Other small glass triodes used in audio equipment include the 6N1P, 6DJ8/6922, 12AT7, 12AU7, 6CG7, 12BH7, 6SN7 and 6SL7.

Many glass power triodes are currently on the market, most of them aimed at amateur radio or high-end audio use. Typical examples are the Svetlana SV300B, SV811/572 series, and 572B. Power triodes come in "low-mu" (low gain) and "high-mu" (high gain) versions. Low-mu triodes like the SV300B have very low distortion and are used in high-end audio amplifiers, while high-mu triodes are used mostly in radio transmitters and big high-power audio amplifiers.

Large ceramic-metal power triodes are often used in radio transmitters and to generate radio energy for industrial heating applications. Specialized triodes of many kinds are made for exotic applications, such as pulsed radars and high-energy physics work.

## **D.Screen grid--the tetrode**

Adding another grid to a triode, between the control grid and the plate, makes it into a TETRODE. This "screen" grid helps screen, or isolate, the control grid from the plate. This is important in reducing the so-called Miller effect, which makes the capacitance between the grid and plate look much bigger than it really is. The screen also causes an electron-accelerating effect, increasing the tube's gain dramatically. The screen grid in a power tube carries some current, which causes it to heat up. For this reason, screen grids are usually coated with graphite, to reduce secondary emission and help keep the control grid cool.

Many large radio and TV stations use giant metal-ceramic power tetrodes, which are capable of high efficiency when used as RF power amplifiers. Power tetrodes are also sometimes used in amateur radio and industrial applications. (Regular tetrodes are rarely used for audio applications because of an effect called "tetrode kink", caused by that secondary emission. Most of it is due to electrons bouncing off the plate, some from the screen.) This greatly increases distortion and can cause instability if not carefully dealt with in the design. See section F, "audio beam tetrodes", below.)

Large ceramic tetrodes are often called "radial beam tetrodes" or simply "beam tetrodes", because their electron emission forms a disc-shaped beam. The wires on their control and screen grids are aligned, a special trick which improves efficiency.

## E. Other grids--the pentode

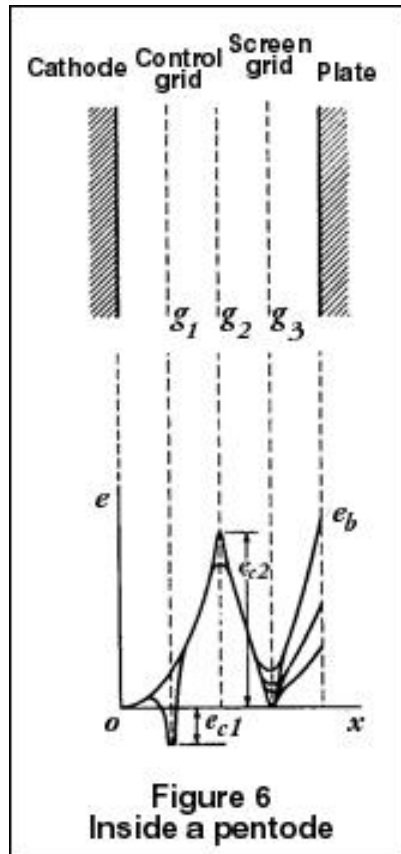

By adding a third grid to the tetrode, we get a PENTODE. The third grid is called a suppressor grid and is inserted between the plate and the screen grid. It has very few wire turns, since its only job is to collect the stray secondary-emission electrons that bounce off the plate, and thereby eliminate the "tetrode kink". It is usually operated at the same voltage as the cathode. Tetrodes and pentodes tend to have higher distortion than triodes, unless special circuit designs are used (see ULTRALINEAR, below).

The EL34, EL84, SV83 and EF86 are true pentodes. The EL34 is widely used in guitar and high-end amplifiers as the power output tube. The smaller EL84 is seen in lower-cost guitar amps. The SV83 is used in a few high-end and guitar amps, while the EF86 is used as a low-noise preamp in guitar amps and professional audio equipment. One of the few large high-power pentodes is the 5CX1500B, often seen in radio transmitters.



There were tubes with more than three grids. The pentagrid converter tube, which had five grids, was widely used as the front-end frequency converter in radio receivers. Such tubes are no longer in production, having been fully replaced by semiconductors.

## **F. Audio Beam Tetrode**

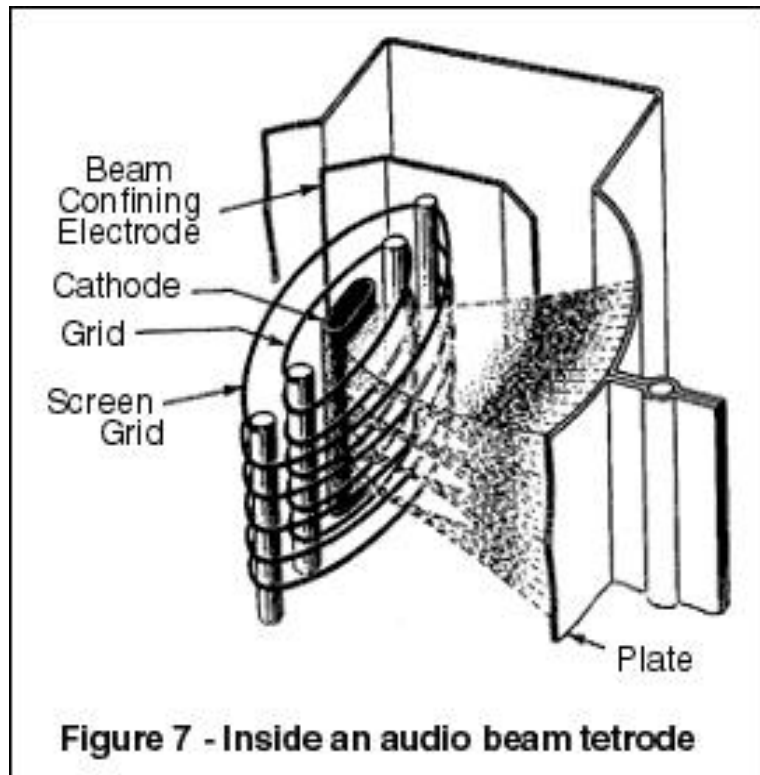

This is a special kind of beam tetrode, with a pair of "beam plates" to constrain the electron beam to a narrow ribbon on either side of the cathode. Also, the control and screen grids have their wire turns aligned, much like the large ceramic tetrodes (above). Unlike the ceramic tetrodes, the grids are at a critical distance from the cathode, producing a "virtual cathode" effect. All this adds up to greater efficiency and lower distortion than a regular tetrode or pentode. The first popular beam tetrode was the RCA 6L6, introduced in 1936. Beam tetrodes still made today include the 6L6GC and 6V650C; the former is most popular in guitar amplifiers, while the latter is the most common power tube in modern high-end audio amplifiers for the home. Today this design is seen only in glass tubes used in audio amplifiers, not in ceramic power tubes.

## G. The heater inside the cathode

An oxide-coated cathode can't heat itself, and it has to be hot to emit electrons. So, a wire filament heater is inserted within the cathode. This heater has to be coated with an electrical insulation that won't burn up at the high temperatures, so it is coated with powdered aluminum oxide. This is an occasional cause of failure in such tubes; the coating rubs off or cracks, so the heater can touch the cathode. This can prevent normal operation of the tube. And if the heater is running from AC power, it can put some of the AC signal into the amplifier's output, making it unusable in some applications. Good-quality tubes have very rugged and reliable heater coatings.

## H. The getter

We want a good, hard vacuum inside a tube, or it will not work properly. And we want that vacuum to last as long as possible. Sometimes, very small leaks can appear in a tube envelope (often around the electrical connections in the bottom). Or, the tube may not have been fully "degassed" on the vacuum pump at the factory, so there may be some stray air inside. The "getter" is designed to remove some stray gas.

The getter in most glass tubes is a small cup or holder, containing a bit of a metal that reacts with oxygen strongly and absorbs it. (In most modern glass tubes, the getter metal is barium, which oxidizes VERY easily when it is pure.) When the tube is pumped out and sealed, the last step in processing is to "fire" the getter, producing a "getter flash" inside the tube envelope. That is the silvery patch you see on the inside of a glass tube. It is a guarantee that the tube has good vacuum. If the seal on the tube fails, the getter flash will turn white (because it turns into barium oxide).

There have been rumors that dark spots on getters indicate a tube which is used. This is NOT TRUE. Sometimes, the getter flash is not perfectly uniform, and a discolored or clear spot can occur. The tube is still good and will give full lifetime. **THE ONLY RELIABLE WAY TO DETERMINE THE HEALTH OF A TUBE IS TO TEST IT ELECTRICALLY.**

Glass power tubes often do not have flashed getters. Instead, they use a metal getter device, usually coated with zirconium or titanium which has been purified to allow oxidation. These getters work best when the tube is very hot, which is how such tubes are designed to be used. The Svetlana 812A and SV811 use such getters.

The most powerful glass tubes have graphite plates. Graphite is heat-resistant (in fact, it can operate with a dull red glow for a long time without failing). Graphite is not prone to secondary emission, as noted above. And, the hot graphite plate will tend to react with, and absorb, any free oxygen in the tube. The Svetlana SV572 series and 572B use graphite plates coated with purified titanium, a combination which gives excellent gettering action. A graphite plate is much more expensive to make than a metal plate of the same size, so it is only used when maximum power capability is needed. Large ceramic tubes use zirconium getters. Since you can't see a "flash" with such tubes, the state of the tube's vacuum has to be determined by electrical means (sometimes by metering the grid current).

## I. Assembling the tube

A typical glass audio tube is made on an assembly line by people wielding tweezers and small electric spot-welders. They assemble the plate, cathode, grids and other parts inside a set of mica or ceramic spacers, then crimp the whole assembly together. The electrical connections are then spot-welded to the tube's base wiring. This work has to be done in fairly clean conditions, although not as extreme as the "clean rooms" used to make semiconductors. Smocks and caps are worn, and each workstation is equipped with a constant source of filtered airflow to keep dust away from the tube parts.



Once the finished assembly is attached to the base, the glass envelope can be slid over the assembly and flame-sealed to the base disc. A small glass exhaust tube is still attached, and enters the envelope. The tube assembly is attached to a processing machine (sometimes called a "sealex" machine, an old American brandname for this kind of device). The exhaust tubing goes to a multistage high-vacuum pump. The sealex has a rotating turntable with several tubes, all undergoing a different step in the process.



- First comes vacuum pumping; while the pump runs, an RF induction coil is placed over the tube assembly and all the metal parts are heated. This helps remove stray gases trapped in the parts, and also activates the cathode coating.
- After 30 minutes or more (depending on the tube type and the vacuum desired), the tube is automatically lifted up and a small flame seals its exhaust tubing.
- The turntable rotates, and there may follow an electrical "break-in" period where the tube is put through a series of operational stresses, such as higher-than-rated heater voltages.
- Then the tube is rotated to the getter-flash station, where a combination of RF induction heating and/or high-voltage discharge flashes the barium getter.

- Finally the tube is removed, the base wiring is attached to the external base (if it is an octal base type) with a special heat-resistant cement, and the finished tube is ready for aging in a burn-in rack. If the tube meets a set of operational specs in a special tester, it is marked and shipped.







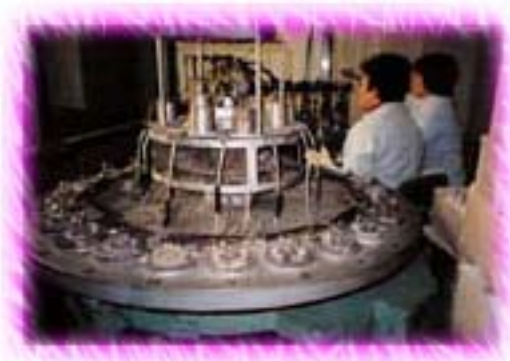

### **J. Metal-ceramic power grid types:**

If you want to control a LOT of power, a fragile glass tube is more difficult to use. So, really big tubes today are made entirely of ceramic insulators and metal electrodes. Otherwise, they are much the same inside as small glass tubes--a hot cathode, a grid or grids, and a plate, with a vacuum in-between.

In these big tubes, the plate is also part of the tube's outer envelope. Since the plate carries the full tube current and has to dissipate a lot of heat, it is made with either a heat radiator through which lots of cooling air is blown, or it has a jacket through which water or some other liquid is pumped to cool it. The air-cooled tubes are often used in radio transmitters, while the liquid-cooled tubes are used to make radio energy for heating things in heavy industrial equipment. Such tubes are used as "RF induction heaters", to make all kinds of products--even other tubes.

Ceramic tubes are made with different equipment than glass tubes, although the processes are similar. The exhaust tubing is soft metal rather than glass, and it is usually swaged shut with a hydraulic press. All the equipment for exhausting and conditioning the tube is much larger, since there is more volume to exhaust, and the large metal parts require more aggressive induction heating. The ceramic parts are usually ring-shaped and have metal seals brazed to their edges; these are attached to their mating metal parts by welding or brazing.



## **WHY ARE TUBES STILL USED?**

### **A. High-power RF applications**

Many big radio stations continue to use big power tubes, especially for power levels above 10,000 watts and for frequencies above 50 MHz. High-power UHF TV stations and large FM broadcast stations are almost exclusively powered by tubes. The reason is cost and efficiency--only at low frequencies are transistors more efficient and less expensive than tubes.

Making a big solid-state transmitter requires wiring hundreds or thousands of power transistors in parallel in groups of 4 or 5 at a time, then mixing their power outputs together in a cascade of combiner transformers. Plus, they require large heat-sinks to keep them cool. An equivalent tube transmitter can use only one tube, requires no combiner (which wastes some power), and can be cooled with forced air or water, thus making it smaller than the solid-state transmitter.

This equation becomes even more pronounced at microwave frequencies. Nearly all commercial communication satellites use a traveling-wave tube for their "downlink" power amplifiers. The "uplink" ground stations also use TWTs. And for high power outputs, the tube seems to reign unchallenged. Exotic transistors still are used only for small-signal amplification and for power outputs of less than 40 watts, even after considerable advances in the technology. The low cost of RF power generated by tubes has kept them economically viable, in the face of advancing science.

### **B. Guitar amps**

In general, only very low-cost guitar amplifiers (and a few specialized professional models) are predominantly solid-state. We have estimated that at least 80% of the market for high-ticket guitar amps insists on all-tube or hybrid models. Especially popular with serious professional musicians are modern versions of classic Fender, Marshall and Vox models from the 1950s and 1960s. This business is thought to represent at least \$100 million worldwide as of 1997.

Why tube amplifiers? It's the tone that musicians want. The amplifier and speaker become part of the musical instrument. The peculiar distortion and speaker-damping characteristics of a beam-tetrode or pentode amp, with an output transformer to match the speaker load, is unique and difficult to simulate with solid-state devices, unless very complex topologies or a digital signal processor are used. These methods apparently have not been successful; professional guitarists keep returning to tube amplifiers.

Even the wildest rock musicians seem to be very conservative about the actual equipment they use to make their music. And their preferences keep specifying the proven technology of vacuum tubes.

## **C. Professional audio**

The recording studio is somewhat influenced by the prevalence of tube guitar amps in the hands of musicians. Also, classic condenser microphones, microphone preamplifiers, limiters, equalizers and other devices have become valuable collectibles, as various recording engineers discover the value of tube equipment in obtaining special sound effects. The result has been huge growth in the sales and advertising of tube-equipped audio processors for recording use. Although still a minor movement within the multi-billion-dollar recording industry, tubed recording-studio equipment probably enjoys double-digit sales growth today.

## **D. High-end audio**

At its low point in the early 1970s, the sales of tube hi-fi equipment were barely detectable against the bulk of the consumer-electronics boom. Yet even in spite of the closure of American and European tube factories thereafter, since 1985 the sales of "high-end" audio components have boomed. And right along with them have boomed the sales of vacuum-tube audio equipment for home use. The use of tubes in this regime has been very controversial in engineering circles, yet the demand for tube hi-fi equipment continues to grow.

## **USING TUBES**

### **A. Bias**

Bias is a negative voltage applied to a power tube's control grid, to set the amount of idle current the tube draws. It is important to bias a tube to stay within its rated dissipation. Otherwise, you DO NOT need to worry about small deviances from the manufacturer's recommendations. Many times we have customers asking us things like, "I replaced the tubes, the old tubes ran at 35 mA, the new ones run at 38 mA. I'm worried that I have to rebias the amp." This is NOT worth worrying about. Especially with guitar amps--they tend to run their tubes at idle conditions which are conservative. Some high-end audio amps run their power tubes quite hard--in that case, rebiasing is necessary. Many amps have no bias adjustments at all, and are designed so that you do not need to concern yourself with bias. This includes most Mesa-Boogie guitar amps, most amps using EL84s, and many single-ended triode hi-fi amps. We suggest that users consult with the equipment manufacturer, if possible.

### **B. When should I replace the tubes?**

Practically speaking, you should only replace tubes in an audio amplifier when you start to notice changes in the sound quality. Usually the tone will become "dull", and transients will seem to be blunted. Also, the gain of the amplifier will decrease noticeably. This is usually enough of a warning for tube replacement. If the user has very stringent requirements for observing tube weakening, the best way to check tubes is with a proper mutual-conductance-style tube tester. These are still available on the used market; though new ones have not been manufactured in many years. One tester is being manufactured today, the Maxi-Matcher. It is suitable for testing 6L6, EL34, 6550 and

EL84 types. If you cannot get your own tube tester, speak to a service technician for his recommendations. See our cathode section 2A above for some idea of typical lifetimes for tubes.

Large ceramic power tubes are usually operated in equipment that has metering of the plate current or power output. When the tube cannot reach the rated plate current or power output for the equipment, the tube is usually considered to be at the end of its normal life. The operating manual should give a more complete procedure for estimating the health of the tube.

### **C. Blue Glow -- what causes it?**

Glass tubes have visible glow inside them. Most audio types use oxide-coated cathodes, which glow a cheery warm orange color. And thoriated-filament tubes, such as the SV811 and SV572 triodes, show both a white-hot glow from their filaments and (in some amplifiers) a slight orange glow from their plates. *All of these are normal effects.* Some newcomers to the tube-audio world have also noticed that some of their tubes emit a bluish-colored glow. There are TWO causes for this glow in audio power tubes; one of them is normal and harmless, the other occurs only in a bad audio tube.

- **1)** Most Svetlana glass power tubes show FLUORESCENCE GLOW. This is a very deep blue color. It can appear wherever the electrons from the cathode can strike a solid object. It is caused by minor impurities, such as cobalt, in the object. The fast-moving electrons strike the impurity molecules, excite them, and produce photons of light of a characteristic color. This is usually observed on the interior of the plate, on the surface of the mica spacers, or on the inside of the glass envelope. THIS GLOW IS HARMLESS. It is normal and does not indicate a tube failure. Enjoy it. Many people feel it improves the appearance of the tube while in operation.
- **2)** Occasionally a tube will develop a small leak. When air gets into the tube, AND when the high plate voltage is applied, the air molecules can ionize. The glow of ionized air is quite different from the fluorescence glow above--ionized air is a strong purple color, almost pink. This color usually appears INSIDE the plate of the tube (though not always). It does not cling to surfaces, like fluorescence, but appears in the spaces BETWEEN elements. A tube showing this glow should be replaced right away, since the gas can cause the plate current to run away and (possibly) damage the amplifier.

PLEASE NOTE: some older hi-fi and guitar amplifiers, and a very few modern amplifiers, use special tubes that DEPEND on ionized gas for their normal operation.

- -Some amps use mercury vapor rectifiers, such as types 83, 816, 866 or 872. These tubes glow a strong blue-purple color in normal use. They turn AC power into DC to run the other tubes.

-And occasionally, vintage and modern amplifiers use gas-discharge regulator tubes, such as types 0A2, 0B2, 0C2, 0A3, 0B3, 0C3 or 0D3. These tubes rely on ionized gas to control a voltage tightly, and normally glow either blue-purple or pink when in normal operation. If you are unsure if these special tubes are used in your amplifier, consult with an experienced technician before replacing them.

ALSO NOTE: these light sources cannot be seen in metal-ceramic tubes, because their parts are opaque. As we said above, it is difficult to tell if a ceramic tube has become gassy. Usually, in a large radio transmitter, a gassy tube will arc over internally. (This does not damage the transmitter. It has protective circuits.) The equipment operating manual should give more information on this.

## **D. What is Class A, B, AB, ultralinear, etc.?**

1. **Class A** means that the power tube conducts the same amount of current all the time, whether idling or producing full power. Class A is very inefficient with electricity but usually gives very low distortion.

- There are single-ended class-A, or SE, amplifiers. They use one or more tubes in parallel, which are all in phase with each other. This is commonly used in smaller guitar amps and in exotic high-end amplifiers. Many audiophiles prefer the SE amplifier, even though it has relatively high levels of even-order distortion. Most 300B high-end amplifiers are SE. Negative feedback, which can be used to decrease the distortion of an amplifier, is felt by some people to sound inferior. Most SE amps have no feedback.
- Push-pull class-A amplifiers also exist--they use two, four or more tubes (always in pairs) which are driven in opposite phase to each other. This cancels out the even-order distortion and gives very clean sound. An example of a class-A push-pull amplifier is the Vox AC-30 guitar amp. Push-pull Class A operation usually involves low plate voltages and high plate currents, compared to Class AB operation below. The high currents might tend to wear out the tube cathodes faster than in an AB amplifier.
- There are two kinds of class-A operation, which can apply to single-ended or push-pull.

--**Class A1** means that the grid voltage is always more negative than the cathode voltage. This gives the greatest possible linearity and is used with triodes such as the SV300B, and with audio beam tetrodes and pentodes.

--**Class A2** means that the grid is driven MORE POSITIVE than the cathode for part or all of the waveform. This means the grid will draw current from the cathode and heat up. A2 is not often used with beam tetrodes, pentodes or triodes like the SV300B, especially in audio. Usually a class-A2 amplifier will use tubes with special rugged grids, such as the SV811 and SV572 series of triodes. Class A2 also requires a special driver circuit that can supply power to the grid.

2. **Class AB** applies only to push-pull amplifiers. It means that when one tube's grid is driven until its plate current cuts off (stops) completely, the other tube takes over and handles the power output. This gives greater efficiency than Class A. It also results in increased distortion, unless the amplifier is carefully designed and uses some negative feedback. There are class-AB1 and class-AB2 amplifiers; the differences are the same as were explained above--the tube's grids are not (AB1) or are (AB2) driven positive.

3. **Class B** applies only to push-pull amplifiers in audio; it SOMETIMES applies to RF power amplifiers with one tube. It is like Class AB, except that the tubes idle at or near zero current. This gives even greater efficiency than Class A or AB. It also results in increased

distortion, unless the amplifier is carefully designed and uses some negative feedback. If careful design is not undertaken, the result may be crossover distortion, which appears at the midpoint of the output waveform and has very bad-sounding effects in audio. Most solid-state audio amplifiers use class B, because the transistors undergo less heat stress when idling.

**4. Ultralinear** operation was invented by David Hafler and Herbert Keroes in 1951. It uses only beam tetrodes or pentodes, and special taps on the output transformer. The taps connect to the screen grids of the tubes, causing the screens to be driven with part of the output signal. This lowers distortion considerably. It is usually seen only in hi-fi amplifiers that use power tubes such as the 6L6GC, 6550C, EL84 or EL34.

**E. Why are different kinds of power supplies used in various tube amplifiers? Why do some use tube amplifiers? Why do some use tube rectifiers, while others use solid-state rectifiers, while still others have electronic regulation?**

Tube rectifiers are still used in power supplies of some guitar amps, because the current a tube rectifier can produce varies somewhat with the load. It is quite different in response from a solid-state rectifier. Many audiophiles also prefer this classic design for much the same reasons. Also, inexpensive solid-state rectifiers can put "hash" into a power supply, because of their slow transient capability while charging and recharging a filter capacitor 50/60 times a second. Special high-speed silicon rectifiers are available at high cost. They are rarely used in products other than a few high-end amplifiers. Tube rectifiers have faster transient response than most solid-state rectifiers, also making them useful in some high-end designs.

Regulated DC plate power can be very helpful in a push-pull Class AB amplifier. Because the amp draws greatly different current when at idle and when delivering full power, a regulated supply "sags" less at full power, producing better transient response in the amplifier. It is expensive to regulate the high voltages in a tube amplifier, so it is done only in expensive top-line models. Class A amplifiers have less need for regulation since they draw nearly the same DC power at all times. It is dependent on the circuit design. The only way to see if you need an amplifier with a regulated supply is to listen to it and carefully compare it with similar amps with unregulated supplies. Regulation is almost never used in guitar amps, since the DC power "sag" causes some signal compression, which is considered part of the desired sound effect inherent to a guitar amp.

**F. What are the advantages of an OTL amplifier over a conventional one with an output transformer? Should I get an OTL? What about its reliability issues?**

OTL, or output-transformerless, amplifiers are special high-end products. Because it is expensive and difficult to wind an output transformer for a tube amplifier to achieve the best possible performance, some designers have chosen to eliminate the transformer altogether. Unfortunately, tubes have relatively high output impedance's compared to transistors. So, tubes with large cathodes and high peak emission capability are used---in many push-pull pairs. A well-designed OTL is capable of the best audio performance available today. OTLs usually require more maintenance and greater care in use than transformer-coupled amps. In recent years, OTLs have gotten a bad reputation for unreliability. This was only a problem with some low-cost manufacturers, who have since gone out of business. A well-designed OTL can be just as reliable as a transformer-coupled amp.

**G. There's all this talk about "parallel feed", "shunt feed", SRPP, "mu followers", and the like. Which should I use? What's the difference?**

Parallel feed and shunt feed are the same technique. Basically, a choke is used to load the power tube (usually one, in SE mode), while the output transformer is coupled to the plate of the tube through a capacitor. So, the plate current of the tube does not flow through the output transformer. This can be a very expensive technique to implement, since the choke must be as carefully wound as the output transformer. It does offer a possible performance improvement. You should try to audition a parallel-feed high-end amp before buying it. This technique is considered too expensive for use in guitar amps.

SRPP circuits and mu-follower circuits are special designs which use a lower tube (for gain), and an upper tube which serves as the plate load for the lower tube. The upper tube also acts as both a cathode follower and as a constant-current source for the lower tube. If properly designed, either circuit can offer improved performance over an ordinary resistor-loaded tube stage. These circuits are used only in preamp stages and in the driver stages of power amps, usually SE types, in high-end audio. If you want to build your own, see Technical Bulletin 27 for a good-quality mu-follower circuit that can be used as a line stage preamp or a power-amp driver.

If you want to learn more of the technical details behind vacuum-tube electronic design, we recommend the following **books**.

- We recommend two recently-published books on circuit design, which the novice can derive much information from:  
**THE BEGINNER'S GUIDE TO TUBE AUDIO DESIGN**, by Bruce Rozenblit (ISBN 1-882580-13-3);  
and **PRINCIPLES OF POWER**, by Kevin O'Connor (ISBN 0-9698-6081-1).
- Classic textbooks on tube audio design which were recently reprinted are:  
**THE RADIO DESIGNER'S HANDBOOK**, by Langford-Smith (ISBN 1-7506-3635-1);  
**FUNDAMENTALS OF RADIO-VALVE TECHNIQUE**, by J. Deketh (ISBN 1-8825-8023-0); and **PRINCIPLES OF ELECTRON TUBES** by Herbert Reich (ISBN 1-882580-07-9).

*These books are more advanced and are not recommended for the novice. They are available from Old Colony Sound Lab, Antique Electronic Supply or other book dealers.*

-All the books above are available from book dealers or from Antique Electronic Supply.

-A web site with much technical information about vacuum tubes is <http://cernan.ecn.purdue.edu/~busenitz/vac.html>

-If you want to learn more about tube materials and processes, the American Institute of Physics currently publishes two classic books that are chock-full of advanced information: **HANDBOOK OF MATERIALS AND TECHNIQUES FOR VACUUM DEVICES**, by Walter Kohl (ISBN 1-56396-387-6); and **HANDBOOK OF ELECTRON TUBE AND VACUUM TECHNIQUES**, by Fred Rosebury (ISBN 1-56396-121-0). All of the books are available from large book dealers and from some of our audio-tube Stocking Distributors. Also see our TUBE FAQ for general information about Svetlana and popular Svetlana products.

## **Tubes vs Transistors: Is there an audible difference?**

Presented September 14, 1972, at the 43rd Convention of the Audio Engineering Society, New York.

Engineers and musicians have long debated the question of tube sound versus transistor sound. Previous attempts to measure this difference have always assumed linear operation of the test amplifier. This conventional method of frequency response, distortion, and noise measurement has shown that no significant difference exists. This paper, however, points out that amplifiers are often severely overloaded by signal transients (THD 30%). Under this condition there is a major difference in the harmonic distortion components of the amplified signal, with tubes, transistors, and operational amplifiers separating into distinct groups.

### **INTRODUCTION:**

As a recording engineer we become directly involved with the tube sound versus transistor sound controversy as it related to pop recording. The difference became markedly noticeable as more solid-state consoles made their appearance. Of course there are so many sound problems related to studio acoustics that electronic problems are generally considered the least of one's worries. After acoustically rebuilding several studios, however, we began to question just how much of a role acoustics played.

During one session in a studio notorious for bad sound we plugged the microphones into Ampex portable mixers instead of the regular console. The change in sound quality was nothing short of incredible. All the acoustic changes we had made in that studio never had brought about the vast improvement in the sound that a single change in electronics had. Over a period of several years we continued this rather informal investigation of the electronic sound problem. In the past, we have heard many widely varied theories that explain the problem, but no one, however, could actually measure it in meaningful terms.

### **PSYCHOACOUSTICS**

Anyone who listens to phonograph records closely can tell that tubes sound different from transistors. Defining what this difference is, however, is a complex psychoacoustical problem. Any investigation of this admittedly subtle phenomenon must really begin with a few human observations. Some people try to point out and describe valid differences. Others just object to the entire thesis and resort to spouting opinions. It is the listener's job to sort out the facts from the fiction.

Electrical engineers, especially the ones who design recording equipment, can prove that there is no difference in tube or transistor sound. They do this by showing the latest specification sheets and quoting electronic figures which are visually quite impressive. It is true, according to the parameters being measured, that there is only a marginal difference in the signal quality. But are there some important parameters which are not being measured? One engineer who admits that there might be some marginal difference in the sound, says, "You just have to get used to the nice clean sound of transistors. What you've been listening to on tubes is a lot of distortion." Of course the question which comes to mind is, What is this distortion and how is it measured?

Psychoacoustically, musicians make more objective subjects than engineers. While their terms may not be expressed in standard units, the musician's "by ear" measuring technique seems quite valid. Consider the possibility that the ear's response may be quite different than an oscilloscope's.

"Tube records have more bass. . . . The bass actually sounds an octave lower," says one rock guitarist. A couple of professional studio players have pointed out on numerous occasions that the middle range of tube recordings is very clear, each instrument has presence, even at very low playback levels. Transistor recordings tend to emphasize the sibilants and cymbals, especially at low levels. "Transistor recordings are very clean but they lack the 'air' of a good tube recording." "With tubes there is a space between the instruments even when they play loud . . . transistors make a lot of buzzing." Two people commented that transistors added a lot of musically unrelated harmonics or white noise, especially on attack transients. This same phenomenon was expressed by another person as a "shattered glass" sound that restricted the dynamics. It was generally agreed that tubes did not have this problem because they overloaded gently. Finally, according to one record producer, "Transistor records sound restricted like they're under a blanket. Tube records jump out of the speaker at you. . . . Transistors have highs and lows but there is no punch to the sound."

When we heard an unusually loud and clear popular-music studio recording, we tried to trace its origin. In almost every case we found that the recording console had vacuum- tube preamplifiers. We are specific in mentioning preamplifiers because in many cases we found hybrid systems. Typically this is a three- or four-track console that is modified with solid-state line amplifiers to feed a solid-state eight- or sixteen-track tape machine. Our extensive checking has indicated only two areas where vacuum-tube circuitry makes a definite audible difference in the sound quality: microphone preamplifiers and power amplifiers driving speakers or disc cutters. Both are applications where there is a mechanical-electrical interface.

As the preliminary basis for our further investigation we decided to look into microphones and preamplifier signal levels under actual studio operating conditions. Hoping to find some clues here we would then try to carry this work further and relate electrical operating conditions to acoustically subjective sound colorations. Our search through published literature showed that little work has been undertaken in this area. Most microphone manufacturers publish extensive data on output levels under standard test conditions [1], but this is rather hard to convert to terms of microphone distances and playing volumes. Preamplifier circuit design is well covered for noise considerations [2], but not from the standpoint of actual microphone operating levels. Distortion has been treated in numerous ways [3-5], but with very few references to musical sound quality [10].

## **MICROPHONE OUTPUT LEVELS**

To get a rough idea of the voltage output from different types of microphones, an oscilloscope was paralleled across inputs of a console. During the normal popular-music type sessions, peak readings of 1 volt or more were common, especially from close-up microphones on voice and drums. Due to the linear voltage scale, oscilloscope measurements over more than a 10-dB range are difficult. By building a simple bipolar logarithmic amplifier, the useful measuring range was extended to about four decades (Fig. 1). Considerable studio observation finally led to the construction of a peak holding type decibel meter. This circuit retained transient peaks of more than 50 microseconds within 2-dB accuracy for about 10 seconds; long enough to write them down. Using the logarithmic oscilloscope display and the peak meter together proved very useful in gathering a wealth of data about real-life microphone signals.



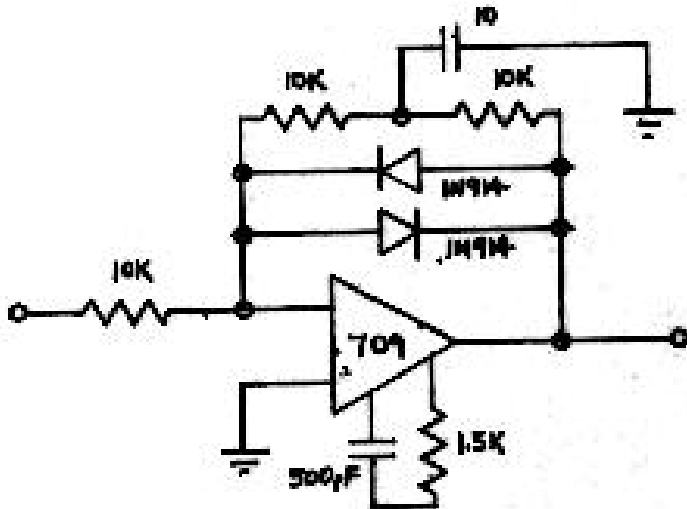

Fig. 1. Simplified bipolar logarithmic amplifier schematic.

Table I shows the normal peak outputs from several popular types of studio microphones. All the readings are taken with the microphone operating into the primary of an unloaded transformer. Pickup distances are indicated for each instrument and were determined by normal studio practice. Table II is an abridgment of a similar studio done by Fine Recording, Inc., several years ago. Details of this test setup are not available but the readings are probably taken without the 6-dB pad commonly used on the U-47 microphone today. Some calculations based on the manufacturer's published sensitivity for these microphones indicated that acoustic sound-pressure levels in excess of 130 dB are common. While the latest console preamplifiers have less noise, less distortion, and more knobs than ever before, they are not designed to handle this kind of input level. In most commercially available preamplifiers, head room runs on the order of +20 dBm, 1 and gain is commonly set at 40 dB. With these basic parameters it is clear from the data shown in Tables I and II that severe overloads can occur on peaks from almost all instruments. For example, a U-87 microphone gives a peak output of -1 dBm from a large floor tom. Amplification by 40 dB in the microphone preamplifier results in an output swing of +39 dBm, or almost 20 dB above the overload point. Logically a peak of this magnitude should be severely distorted.

**Table 1. Peak microphone output levels for percussive sounds.**

Microphone Voltage, Open Circuit, dB Ref. 0.775 V

Instrument	Distance (in)	U-87	U-47	77-DX	C-28	666
Bass Drum (single head)	6	0	-6	-9	-15	-1
Large tom tom	12	-1	-6	-9	-10	-5
Small tom tom	12	-1	-5	-7	-9	-1
Piano (single note)	6	-25	-29	-38	-35	-32
Piano (chord)	6	-23	-27	-36	-33	-33
Orchestra bells	18	-16	-25	-33	-33	-30
Cow bell	12	-10	-12	-29	-19	-15
Loud yell	4	0	-11	---	-10	-10

(U-87 and U-47 by Neumann, 77-DX by RCA, C-28 by AKG, 666 by Electro-Voice)

Table 1. Peak microphone output levels for percussive sounds. Microphone Voltage, Open Circuit, dB Ref. 0.775 V (U-87 and U-47 by Neumann, 77-DX by RCA, C-28 by AKG, 666 by Electro-Voice)

Most recording consoles today have variable resistive pads on the microphone inputs to attenuate signal levels which are beyond the capabilities of the preamplifier. The common use of these input pads supposedly came about with the advent of loud rock music; however, this is not true in fact. For some 20 years it has been common to use a Neumann U-47 microphone for close microphone recording of brass and voice. Table II shows output levels requiring 10-20 dB of padding under these conditions, and this does agree with recording practice today where solid-state amplifiers are used. But most tube consoles did not have input pads and yet the same microphone performed with little noticeable distortion. Certainly brass players and singers are not that much louder today than they were yesterday. The microphone distance is about the same. The preamplifier specifications have not changed that much. Yet transistors require pads and tubes do not.

**Table 2. Peak output for a U-47 microphone for various sounds.**

<b>Instrument</b>	<b>Distance (ft)</b>	<b>Peak Pressure Frequency (Hz)</b>	<b>Microphone Voltage (dB Ref. 0.775V)</b>
75-piece orchestra	15	350	-10
15-piece orchestra	10	350	-12
Trumpet	3	600	-16
Trombone	3	600	-15
French horn	3	300	-13
Flute	3.5	800	-26
Piccolo	3.5	2500	-18
Clarinet	3.5	350	-22
Bass sax	3.5	350	-8
Bass viol	5	150	-13

Here then is the hypothesis for further investigation. In the usual evaluation of audio preamplifiers it is assumed that they are operated in their linear range, i.e., harmonic distortion less than 10%. In this range tubes and transistors do have very similar performance characteristics. But the preceding section points out that amplifiers are often operated far out of their linear range at signal levels which would cause severe distortion. Under these conditions, tubes and transistors appear to behave quite differently from a sound viewpoint.

## **DISTORTION CHARACTERISTICS OF PREAMPLIFIERS**

Three commercially available microphone preamplifiers of different designs were set up in the recording studio. Each amplifier was adjusted for a gain of 40 dB and an overload point of 3% total harmonic distortion (THD) at +18 dBm. Preamplifier 1 was a transistor design, preamplifier 2 was a hybrid operational amplifier, and preamplifier 3 was a vacuum-tube triode design. The amplifier outputs were terminated in 600-ohm loads and bridged by the monitoring system. The test signal, U-87 microphone, and large floor tom were switchable to each preamplifier input.

An informal group of studio personnel listened to the outputs of the three amplifiers on the normal control room monitor speakers. As the test signal was switched from one amplifier to another, listeners were asked to judge the sound quality. The output of amplifiers 1 and 2 was unanimously judged to be severely distorted. Amplifier 3, however, sounded clean. The test was repeated several times inserting attenuating pads in the microphone line until each amplifier sounded undistorted. Amplifier 1 could stand overloads of 5-10 dB without noticeable distortion. Amplifier 2 showed noticeable distortion at about 5 dB overload. Further listening revealed that it was only in the range of early overload where the amplifiers differed appreciably in sound quality. Once the amplifiers were well into the distortion region, they all sounded alike -- distorted. In their normal non-overload range all three amplifiers sounded very clean.

The listening tests clearly indicate that the overload margin varies widely between different types of amplifiers. Engineering studios show that any amplifier adds distortion as soon as the overload point is reached. The tests show that all amplifiers could be overloaded to a certain degree without this distortion becoming noticeable. It may be concluded that these inaudible harmonics in the early overload condition might very well be causing the difference in sound coloration between tubes and transistors.

To get a general representation of the character of harmonic distortion in audio amplifiers, overload curves were plotted for about fifty different circuits. The tube circuits used the popular 12AY7 and 12AX7 triodes, the 8628 and 7586 triode nuvistors, and the 5879 pentode. These tubes have all been extensively used in recording console preamplifiers.

The 2N3391A, 2N5089, and 2N3117 silicon PNP transistors were also chosen because of their extensive use in console and tape recorder circuitry. For comparison purposes tests were also run on the 2N5087 which is the PNP sister of the 2N5089. Operational amplifiers included the popular 709 and LM301 monolithic units and two commercially available hybrid designs used in recording consoles.

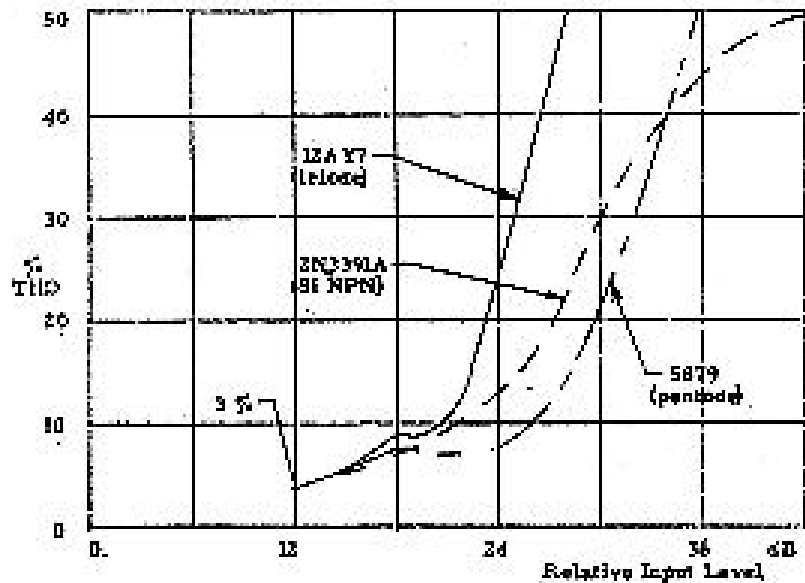

Fig. 2. Single-stage amplifier comparison of total harmonic distortion (THD).

The curves shown in Fig. 2 are representative of the general distortion characteristics of single-stage class A audio amplifiers. The devices are all operating open loop (no feedback) with a bias point which allows for maximum undistorted output swing. The curves are referenced to a common point of 3% (THD), regardless of actual input or output levels. Since the objective of these comparisons is to detect variations in the slopes of the distortion characteristics, the x axis is a scale of relative level independent of circuit impedance considerations. These particular curves were chosen from the many plotted as representative of different families: silicon transistors, triodes, and pentode. A quick look shows that the often versed opinion that tubes overload more gently than transistors is obviously a myth.

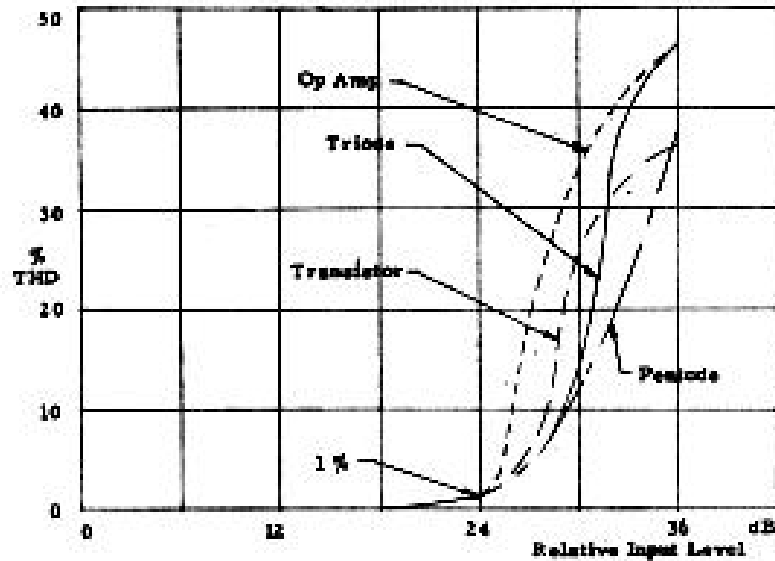

Fig. 3. Multistage amplifier comparison of total harmonic distortion (THD).

Fig. 3 shows the distortion characteristics for four different commercially available preamplifiers, using two or more stages of amplification. All the circuits use feedback, a couple are push-pull. Each amplifier is operating into 600 ohms at a gain of 40 dB. As in the previous curves, there is a common reference point of 1% THD. While these curves show a marked difference from the single-stage amplifiers, a review of the many different amplifiers tested shows that the slopes of all THD curves run about the same. The lack of a wide variation between the curves indicates that THD plots are not very relevant to what the ear hears in the listening tests.

Another series of tests were made on the same group of preamplifiers using a spectrum analyzer to measure the amplitude of individual harmonics. Each amplifier was driven 12 dB into overload, starting from a reference point of 1% third harmonic distortion. Every harmonic to the seventh was plotted. Since it is not possible to measure the relative phase of the harmonics on the spectrum analyzer, the overload waveforms were recorded for Fourier analysis on the digital computer. The resulting plots divided amplifiers into three distinct categories.

## 1) Tube Characteristics

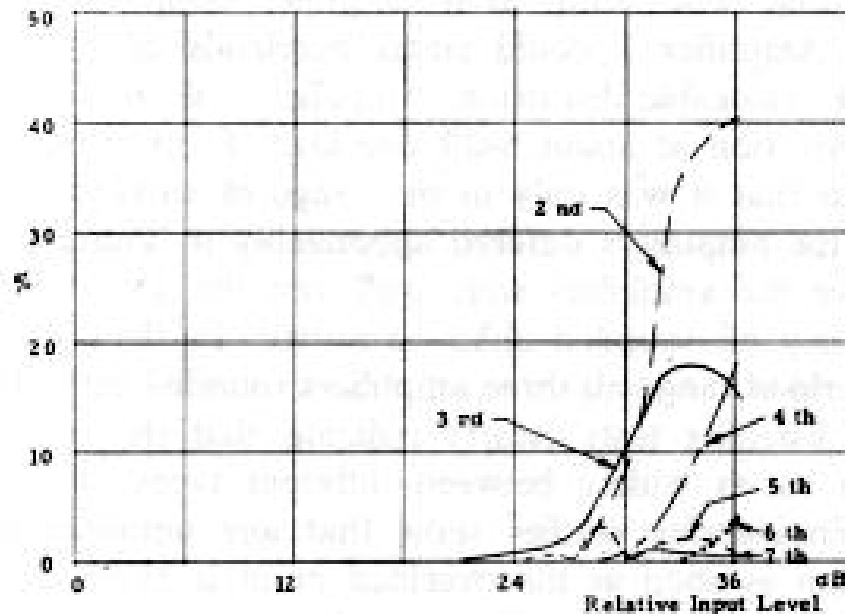

Fig. 4. Distortion components for two-stage triode amplifier.

Fig. 4 shows the distortion components for a typical two-stage 12AY7 amplifier. This particular design is quite representative of several single-ended, multistage triode tube amplifiers tested. The outstanding characteristic is the dominance of the second harmonic followed closely by the third. The fourth harmonic rises 3-4 dB later, running parallel to the third. The fifth, sixth, and seventh remain below 5% out to the 12-dB overload point. These curves seem to be a general characteristic of all the triode amplifiers tested, whether octal, miniature, nuvistor, single-ended, or push-pull. Fig. 5 is the waveform at 12 dB of overload. The clipping is non-symmetrical with a shifted duty cycle. Again this is a characteristic of all the triode amplifiers tested.

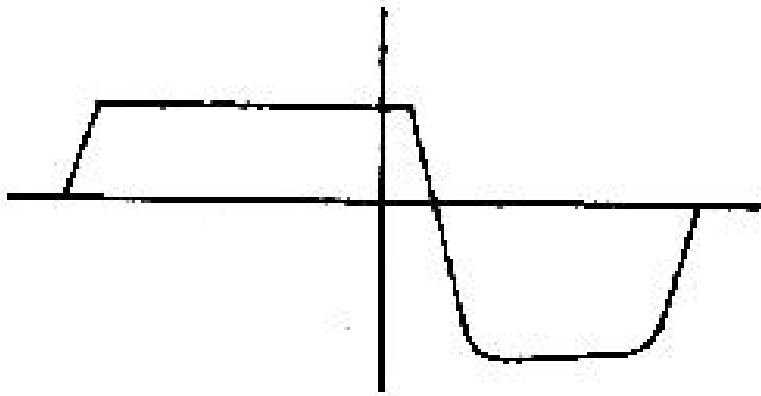

Fig. 5. Waveform of triode amplifier of Fig. 4 at 12-dB overload. 1000-Hz tone

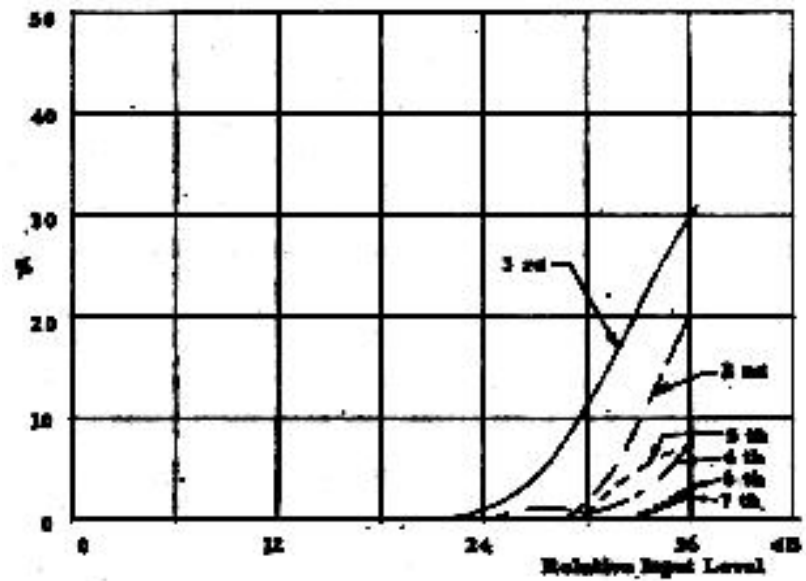



Fig. 6. Distortion components for two-stage pentode amplifier.

Fig. 6 shows the distortion components for a two-stage single-ended pentode amplifier. Here the third harmonic is dominant and the second rises about 3 dB later with the same slope. Both the fourth and fifth are prominent while the sixth and seventh remain under 5%. The waveform at 12-dB overload (Fig. 7), is similar to the triode, but its duty cycle is not shifted as much. It is not reasonable to assume that virtually all tube amplifiers can be represented by these two examples. However, the major characteristic of the tube amplifier is the presence of strong second and third harmonics, sometimes in concert with the fourth and fifth, but always much greater in amplitude. Harmonics higher than the fifth are not significant until the overload is beyond 12 dB. These characteristics seem to hold true for wide variations in circuit design parameters. The extreme difference in the tube amplifiers is the interchanging of the position of the second and third harmonics. This effect is not just a characteristic of the pentode, it is common to triodes too.

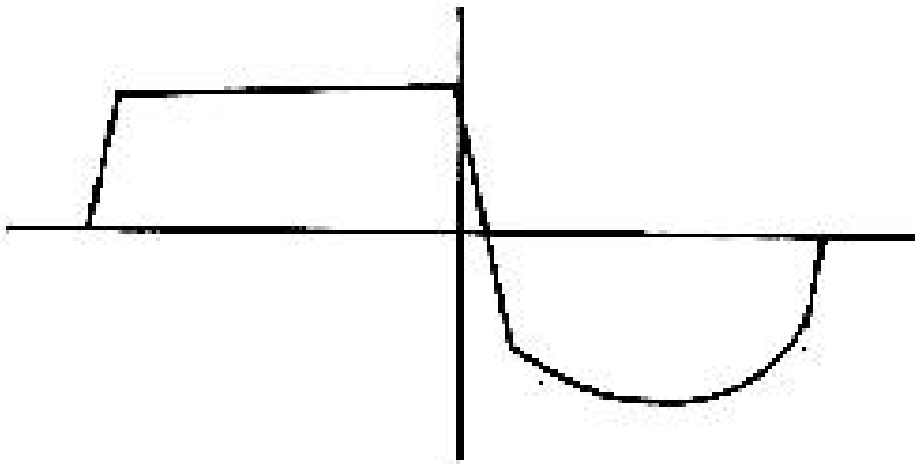

Fig. 7. Waveform of pentode amplifier of Fig. 6 at 12 dB overload, 1000-Hz tone.

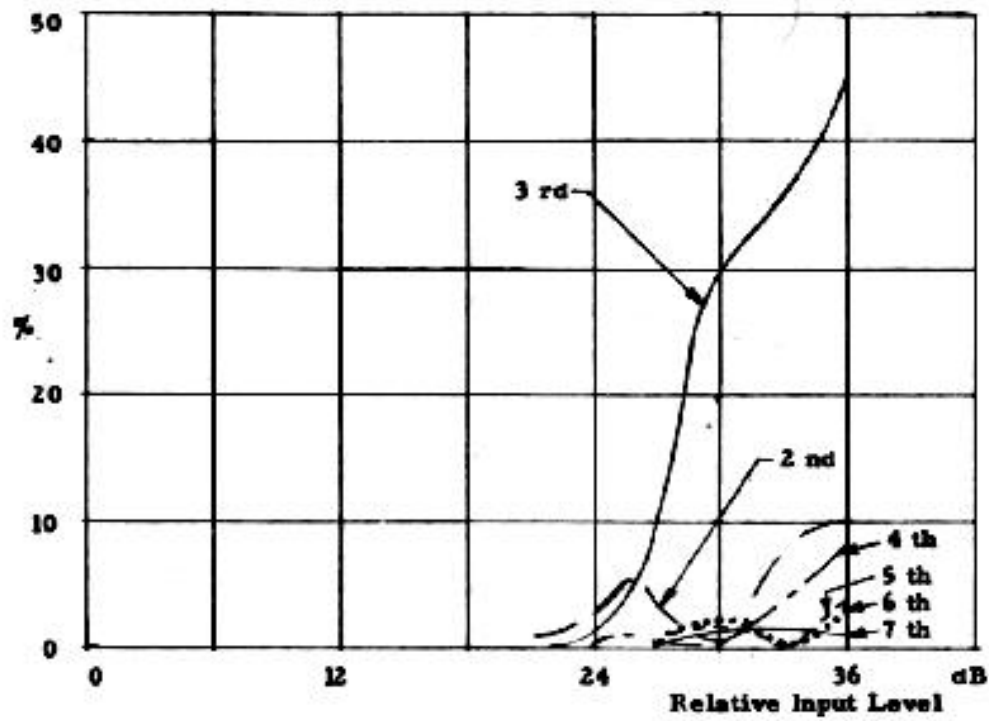

Fig. 8. Distortion components for multistage capacitor-coupled transistor amplifier.

## 2) Transistor Characteristics

Figs. 8 and 10 show the characteristics of two transistor amplifiers. Like the previous figures the curves are representative of all the transistor amplifiers tested. The distinguishing feature is the strong third harmonic component. All other harmonics are present, but at a much lower amplitude than the third. When the overload reaches a break point, all the higher harmonics begin to rise simultaneously. This point is generally with 3-6 dB of the 1% third harmonic point. The waveforms of these amplifiers (Figs. 9 and 11) are distinctly square wave in form with symmetrical clipping and an almost perfect duty cycle. Both amplifiers shown have single-ended inputs and push-pull outputs. However, the circuit designs are radically different.

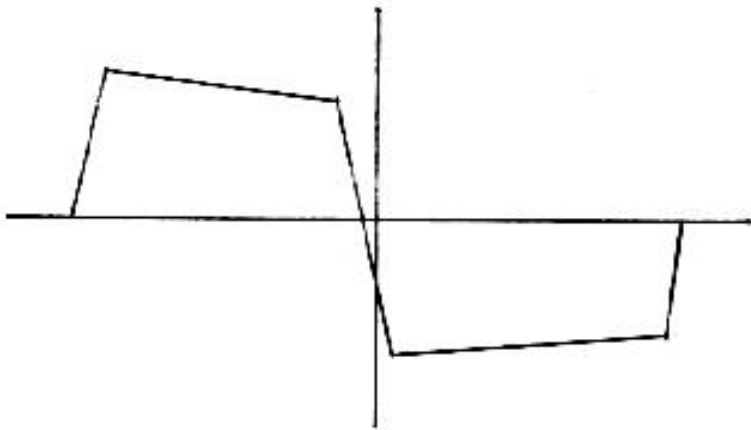

Fig. 9. Waveform for transistor amplifier of Fig. 8 at 12-dB overload, 1000-Hz tone.

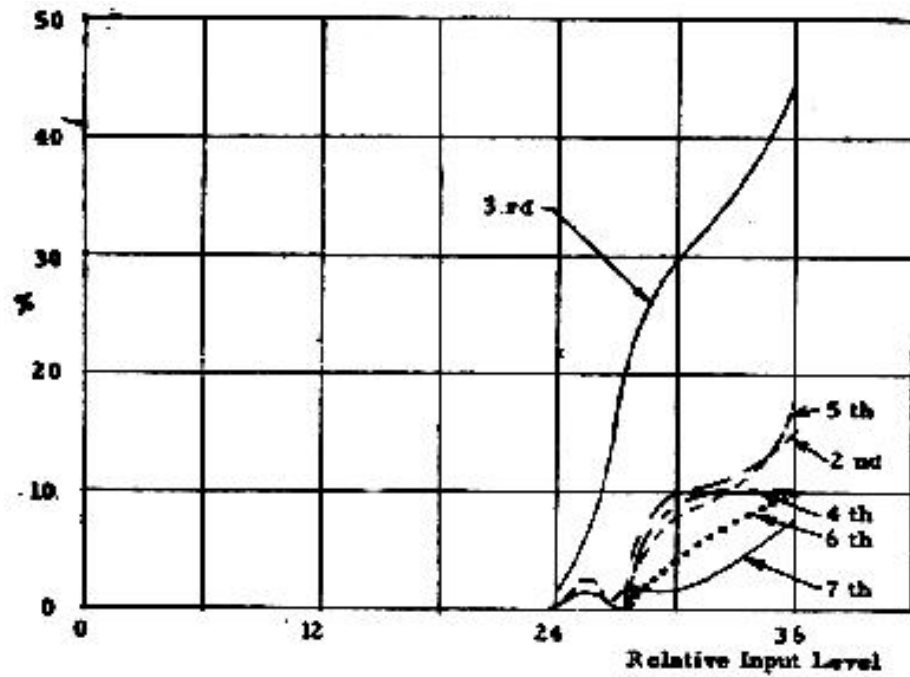

Fig. 10. Distortion components for multistage transformer-coupled transistor amplifier.

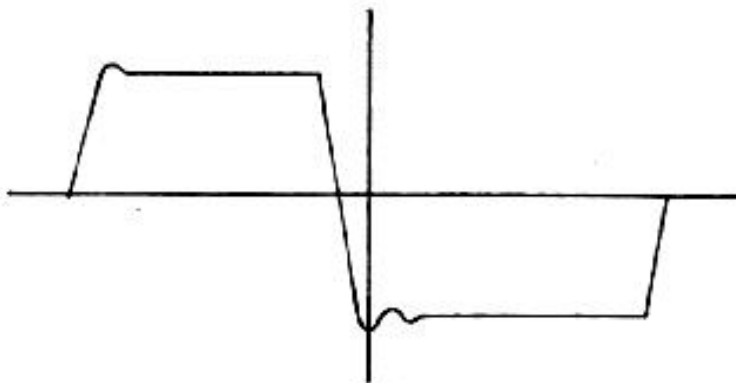

Fig. 11. Waveform for transistor amplifier of Fig. 10 at 12-dB overload, 1000-Hz tone.

### 3) Operational-Amplifier Characteristics

Fig. 12 is a hybrid operational amplifier. The third harmonic rises steeply as the dominant distortion component in a characteristic similar to the transistor. Also rising very strongly from the same point are the fifth and seventh harmonics. All even harmonics are suppressed completely. The waveform of Fig. 13 is a perfect square wave. As a classification group, operational amplifiers have the most uniform characteristics with almost no deviation from the curves shown in this example.

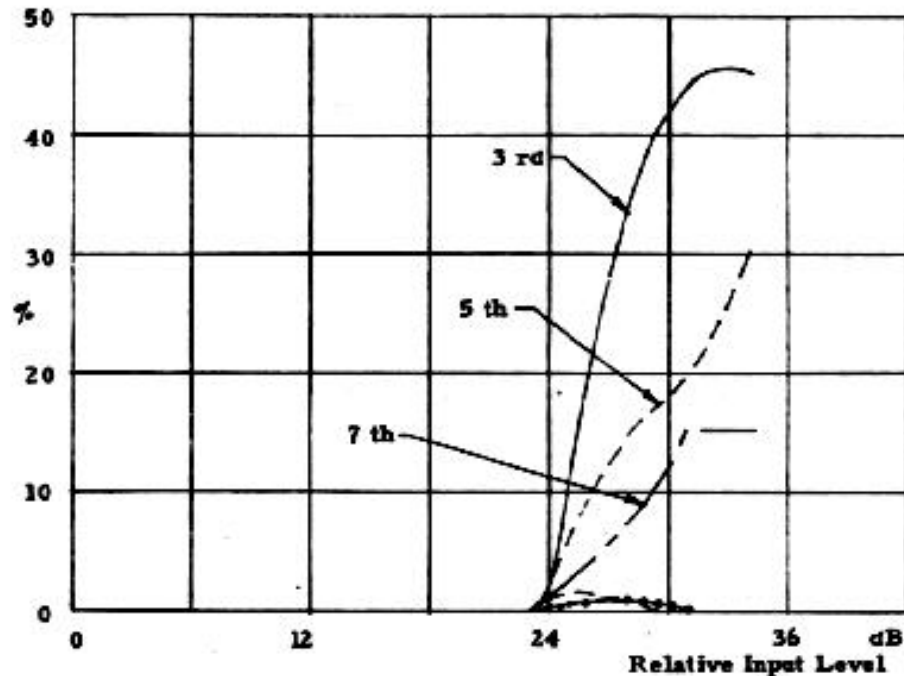

Fig. 12. Distortion components for monolithic operational amplifier with hybrid output stage.

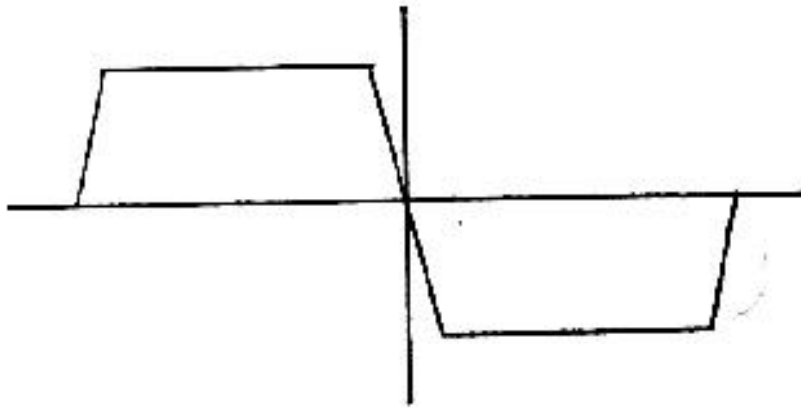

Fig. 13. Waveform for operational amplifier of Fig. 12 at 12-dB overload, 1000-Hz tone.

In view of the transient nature of audio signals, steady-state single-frequency distortion analysis could yield questionable results. Indeed, the arguments for and against sine-wave and pulse test signals for audio system testing have been the subject for a number of engineering papers [4], [7]. For our purposes, however, a few minutes toying with an electronic synthesizer quickly proved that musical instruments do not produce fast pulses. For example, a good simulation of the large floor tom used in the amplifier listening tests is a 100-Hz tone modulated with an envelope rise time of 5 ms and a decay time of 300 ms. Also an extensive study of trumpet tones [6] measured the rise time of the fastest staccato notes at 12 ms. Certainly, rise times of these orders can not be considered pulses for audio amplifiers with pass bands extending to 20 kHz or better. Just to further prove the correctness of the preceding steady-state results, the synthesized floor tom signal was used to test the same amplifiers at the same level as the microphone signal.

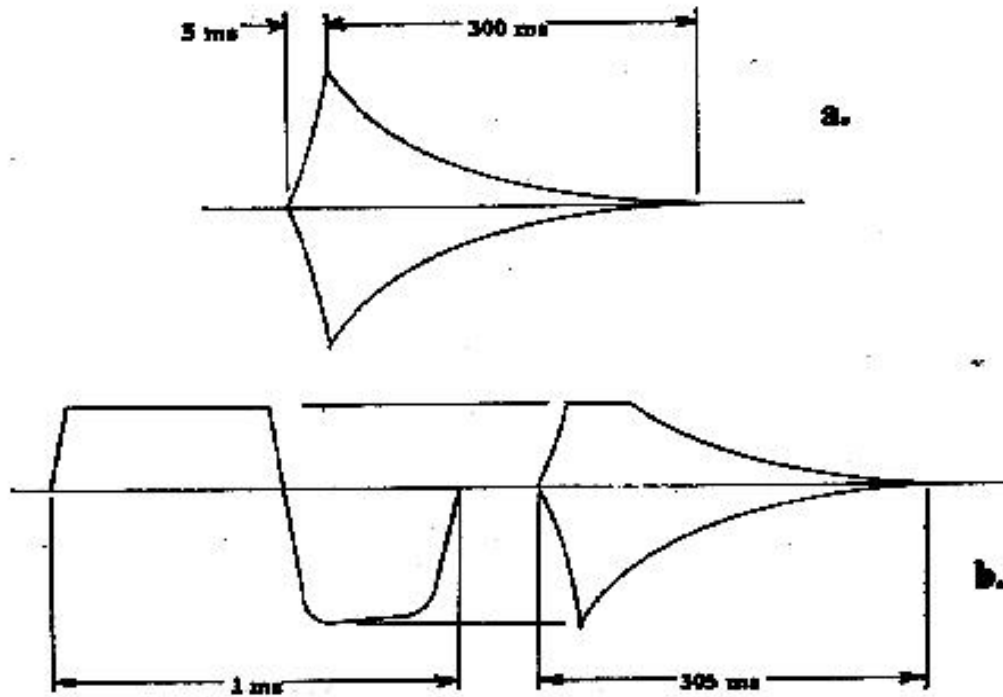

Fig. 14. a. Envelope of Moog-generated floor tom test signal. b. Envelope clipping of transient signals by amplifier is identical to single-frequency clipping levels.

Careful observation of the amplified signal showed that envelope clipping was identical to the steady-state clipping level (Fig. 14). There were no glitches or other fast transient phenomena in the output signal.

## **SIGNIFICANCE OF MUSICAL HARMONICS**

Having divided amplifiers into three groups of distortion characteristics, the next step is to determine how the harmonics relate to hearing. There is a close parallel here between electronic distortion and musical tone coloration that is the real key to why tubes and transistors sound different. Perhaps the most knowledgeable authorities in this area are the craftsman who build organs and musical instruments [8], [9]. Through many years of careful experimentation these artisans have determined how various harmonics relate to the coloration of an instrument's tonal quality.

The primary color characteristic of an instrument is determined by the strength of the first few harmonics. Each of the lower harmonics produces its own characteristic effect when it is dominant or it can modify the effect of another dominant harmonic if it is prominent. In the

simplest classification, the lower harmonics are divided into two tonal groups. The odd harmonics (third and fifth) produce a "stopped" or "covered" sound. The even harmonics (second, fourth, and sixth) produce "choral" or "singing" sounds.

The second and third harmonics are the most important from the viewpoint of the electronic distortion graphs in the previous section. Musically the second is an octave above the fundamental and is almost inaudible; yet it adds body to the sound, making it fuller. The third is termed quint or musical twelfth. It produces a sound many musicians refer to as "blanketed." Instead of making the tone fuller, a strong third actually gives the sound a metallic quality that gets annoying in character as its amplitude increases. A strong second with a strong third tends to open the "covered" effect. Adding the fourth and fifth to this changes the sound to an "open horn" like character.

The higher harmonics, above the seventh, give the tone "edge" or "bite." Provided the edge is balanced to the basic musical tone, it tends to reinforce the fundamental, giving the sound a sharp attack quality. Many of the edge harmonics are musically unrelated pitches such as the seventh, ninth, and eleventh. Therefore, too much edge can produce a raspy dissonant quality. Since the ear seems very sensitive to the edge harmonics, controlling their amplitude is of paramount importance. The previously mentioned study of the trumpet tone [6] shows that the edge effect is directly related to the loudness of the tone. Playing the same trumpet note loud or soft makes little difference in the amplitude of the fundamental and the lower harmonics. However, harmonics above the sixth increase and decrease in amplitude in almost direct proportion to the loudness. This edge balance is a critically important loudness signal for the human ear.

## **RELATIONSHIP OF FACTORS AND FINDINGS**

The basic cause of the difference in tube and transistor sound is the weighting of harmonic distortion components in the amplifier's overload region. Transistor amplifiers exhibit a strong component of third harmonic distortion when driven into overload. This harmonic produces a "covered" sound, giving a recording a restricted quality. Alternatively a tube amplifier when overloaded generates a whole spectrum of harmonics. Particularly strong are the second, third, fourth, and fifth overtones, which give a full-bodied "brassy" quality to the sound. The further any amplifier is driven into saturation, the greater the amplitude of the higher harmonics like the seventh, eighth, ninth, etc. These add edge to the sound which the ear translates to loudness information. Overloading an operational amplifier produces such steeply rising edge harmonics that they become objectionable within a 5-dB range. Transistors extend this overload range to about 10 dB and tubes widen it to 20 dB or more. Using this basic analysis, the psychoacoustic characteristics stated in the beginning of this paper can be related to the electrical harmonic properties of each type of amplifier.

It was not part of the original intent of this paper to analyze operational amplifiers. However, the tests show that they fall into a distinct class of their own. Basically, operational amplifiers produce strong third, fifth and seventh harmonics when driven only a few dB into overload. The resultant sound is metallic with a very harsh edge which the ear hears as strong distortion. Since this sound is so objectionable, it acts as a clearly audible overload warning signal. Consequently, operational amplifiers are rarely operated in their saturation region. This results in a very cleanly amplified sound with little coloration and true dynamic range within the limitations of the amplifier. True dynamic range is not necessarily the determinant of good sound reproduction, however, since it is much greater than any disc or tape system presently available. Because of their characteristics, operational amplifiers produce only the top end of the dynamic range which contains all the transients but lacks the solid pitch information which the ear hears as music. When records of true dynamic range are played on a limited-



range system, they sound very thin. This relates directly to the originally cited listener's comment that transistor records were very clean but sounded sibilant and cymbally.

The transistor characteristics which our subjects noted were the buzzing or white-noise sound and the lack of "punch." The buzz is of course directly related to the edge produced by overloading on transients. The guess that this is white noise is due to the fact that many of the edge harmonics like the seventh and ninth are not musically related to the fundamental. The ear hears these dissonant tones as a kind of noise accompanying every attack. The lack of punch is due to the strong third harmonic which is inaudibly "blanketing" the sound. This is correctable by using a large enough pad to prevent all peaks from reaching the amplifier's saturated region. But from a practical standpoint, there is no way of determining this on most consoles. Adding auxiliary peak indicators on the input preamplifiers could alleviate both these problems, and the sound would be very close to that of the operational amplifier in its linear region.

Vacuum-tube amplifiers differ from transistor and operational amplifiers because they can be operated in the overload region without adding objectionable distortion. The combination of the slow rising edge and the open harmonic structure of the overload characteristics form an almost ideal sound- recording compressor. Within the 15-20 dB "safe" overload range, the electrical output of the tube amplifier increases by only 2-4 dB, acting like a limiter. However, since the edge is increasing within this range, the subjective loudness remains uncompressed to the ear. This effect causes tube-amplified signals to have a high apparent level which is not indicated on a volume indicator (VU meter). Tubes sound louder and have a better signal-to-noise ratio because of this extra subjective head room that transistor amplifiers do not have. Tubes get punch from their naturally brassy overload characteristics. Since the loud signals can be recorded at higher levels, the softer signals are also louder, so they are not lost in tape hiss and they effectively give the tube sound greater clarity. The feeling of more bass response is directly related to the strong second and third harmonic components which reinforce the "natural" bass with "synthetic" bass [5]. In the context of a limited dynamic range system like the phonograph, recordings made with vacuum-tube preamplifiers will have more apparent level and a greater signal to system noise ratio than recordings made with transistors or operational amplifiers.

## REFERENCES

[1] "Neumann Transistor Condensor Microphones," Gotham Audio Corp., Sales Bulletin (1971).

[2] A. D. Smith and P. H. Wittman, "Design Considerations of Low-Noise Audio Input Circuitry for a Professional Microphone Mixer," J. of the Audio Eng. Soc., vol. 18, pp. 140-156 (April 1970).

[3] A. Schaumberger, "The Application of Impulse Measurement Techniques to the Detection of Linear Distortion," J. of the Audio Eng. Soc., vol. 19, pp. 664-668 (Sept. 1971).

[4] M. Ojala, "Circuit Design Modifications for Minimizing Transient Intermodulation Distortion in Audio Amplifiers," J. of the Audio Eng. Soc., vol. 20, pp. 396-399 (June 1972)

[5] F. Langford-Smith, Radiotron Designer's Handbook (RCA, 1953), chapter 14.

- [6] J. C. Risset, "Computer Study of Trumpet Tones," Bell Telephone Laboratories, File MM-66-1222-2.
- [7] J. R. Ashley, T. A. Saponas, and R. C. Matson, "Test Signals for Music Reproduction Systems," IEEE Spectrum, vol. 8, pp. 53-61 (July 1971).
- [8] A. H. Benade, Horns, Strings and Harmony, (Doubleday, New York, 1960).
- [9] R. A. Schaefer, "New Techniques for Organ Tone Generation," J. of the Audio Eng. Soc., vol. 19, pp. 570-575 (July/Aug. 1971).
- [10] R. Langevin, "Intermodulation Distortion in Tape Recording," J. of the Audio Eng. Soc., vol. 11, pp. 270-278 (July 1963).

## **TUBE VARIABILITY – THE MOST VARIABLE COMPONENT IN YOUR AMPLIFIER**

A vacuum tube is very complex. It looks to be a very simple device, but is anything but simple. In your amp, you may have +/- 20% resistors, and other items of wide tolerances, but vacuum tubes can, and will vary, much more.

A typical preamp tube such as the common 12AX7 / ECC83 / 7025 will have many construction variations. There are long plates, smooth plates, box plates, rib plates .... Long and short cathodes, differences in construction. These aspects, and many more, lend to changes in tone and response. Even tubes of the SAME MAKE, SAME TYPE, and SAME MAKER from the same batch, will vary widely.

A typical 12AX7R2 as made in the Reflector Factory and distributed under the Sovtek name, will have Transconductance ranging from 900 to 2000, as one example. The target spec is 1600, As you can see from some simple math, this is WAY outside of the +/- 20% range of your resistors or other components. Output in milliamps, expected to be 1.2 milliamps at 250 plate volts and -1.2 volt bias, in these tubes shows 0.6mA to 1.6mA. The average is about 0.8 (about 30% less than expectation spec by the way). Gain (not the same as output), and plate resistance also vary widely. This is one reason that when you retube your amp with fresh and new tubes, at times you may find, the amp has lost it's life. Why? Your old V1 may have been putting out 0.9 milliamps in current ... your new tube has 0.6 milliamps, 30% less current output than your "old" tube. What can you do about this? Your best option is to use a tube vendor that tests ALL preamp tubes for things like low output, low noise, and lack of microphonics. Many rely on just sending all their tubes out to the customers, relying on a warranty to take care of the testing for them. In most cases, it is not worth the trouble for the customer to send back one single tube, box, ship, and the post office line ...they just forget it.

Why are tubes so variable? First off, there is a LOT of hand assembly. This is not like making silicon devices on AMD or INTEL production equipment. There are also a LOT of materials, and the ratio of many of these materials is very critical. Change a plate material or cathode coating, and you may have changes. Move things around in production and you will have changes. There are many aspects that can change tubes, even the weather during production. These little glass bottles are generally not made in a silicon clean room environment.

What sorts of materials can change? How can it be complicated ... some metal and glass? Sure, we know that metallurgy is an exact science, and when it comes to airplanes or high tech items, this is paramount. But, in vacuum tubes, it generally does not share the same attention – one more variable.

The tubes use a number of materials. Some of them are mish metal, nigrosine, porcelain, petroleum jelly, zinc, calcium aluminium fluoride, resin (synthetic), ethyl alcohol, lead acetate, malachite green, glycerine, zinc chloride, iron, marble dust, wood fiber, strontium nitrate, lead oxide, zinc oxide, lava, mica, tin, sodium carbonate, sodium nitrate, silver oxide, barium carbonate, calcium carbonate, arsenic trioxide, ammonium chloride, strontium carbonate, potassium carbonate, isolanlite, bakelite, molybdenum, phosphorus, alumina, silicon, borax, shellac, tungsten, barium, copper, titanium, carbon, silica, glass, chromium, magnesia, calcium, platinum, caesium, cobalt, strontium, iridium, magnesium, monel, rosin, nickel, calcium oxide, cobalt oxide, barium nitrate, thorium nitrate. Actually a somewhat complex recipe!

After all these ingredients are “mixed”, we still have all the variability of assembly and manufacture. Remember when I said that a lot of this is done by hand? Even the machine aspects are pretty tight in the tolerance department, so the machines must be kept within close tolerances, which is not always the case due to wear or lack of attention to maintenance.

How close are these tolerances? Lets look at some of them in a typical output tube where there is more room to work than in a preamp tube, so this is “easy”.

Grids – the diameter of the grid has to be 0.001 inch. Cathode sleeve wall – 0.002 inches thick. Air pressure – 1/100,000,000<sup>th</sup> of sea level.

The glass bulb – inspected under polarized light for stains. The Plate – diameter gauged to 0.002 inches. Cathode coating – weight variation less than 0.0007 ounce.

Grid wire – diameter cannot vary more than 0.00009 inch. Heater wire – diameter cannot vary more than 0.0002 inch.

So, now we have the basic “parts” from the most easily recognized major aspects of a tube, yet we still are looking at putting it all together, welding or attaching it all somehow, and expecting it all to not only work, but work in an expected manner. It is pretty amazing, that today, these things even work at all!

## Matched Phase Inverters and Drivers

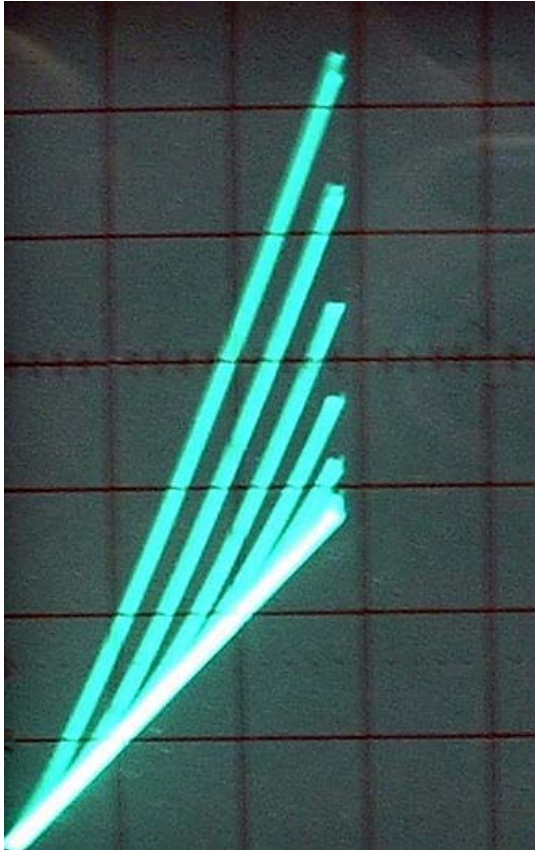

An example of an “almost matched” dual triode. In the longest leg of this trace, you will notice at one voltage level range at the top, there is one trace higher than the one attached to it. Many folks match for gain, some for output, some for transconductance, and none that I know of match for rise time. This would be considered a pretty amazing tube. Most (45+ out of 50) have the two traces not even close in any single aspect of it's specs, let alone close in all aspects. This takes a LOT of time to match a tube in this way, but a lot of folks can sure hear the results in great amps. In amps with all sort of mismatched aspects, there is a lot of work that needs to be done before the total benefits of a phase inverter even this closely matched can be fully appreciated.

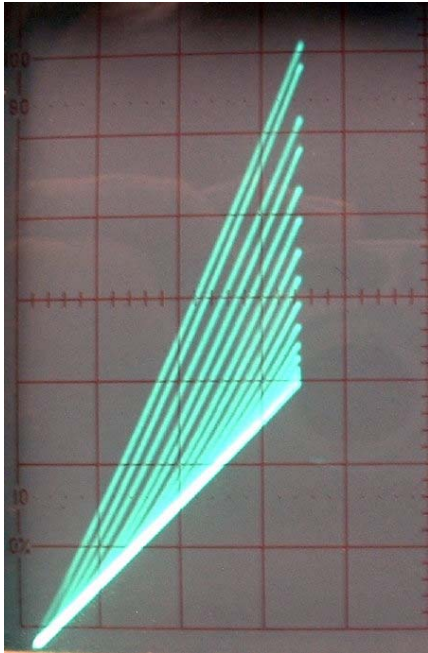

This is what was termed a “matched tube” from a very high end audio vendor. It is obvious to me, that it was rated, so to speak, by some value, perhaps TC or transconductance, being within some range or percent. The output of the two sides differ, their rise time differs also.

Here we see all 12 traces, rather than the 6 we saw above.

By the way, this is a very nicely “matched” tube compared to 90% that comes directly from the factory, or tube that are billed as NOS that are some of the last of the “pulls” or tubes that have been banged around for a few decades.

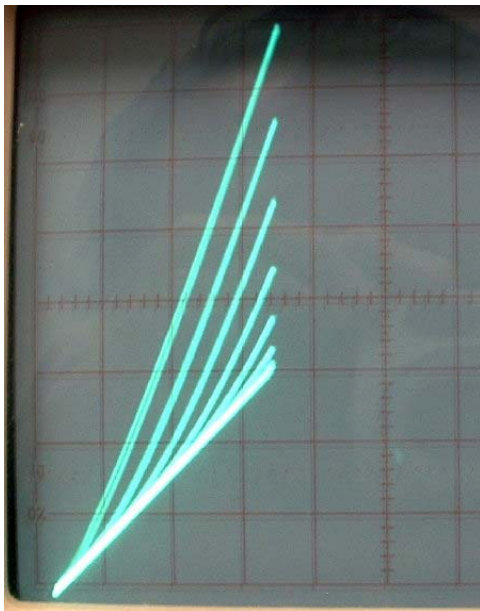

This is a true MPI – or matched phase inverter.

You are seeing the tube swept over six ranges – what looks to be six lines. There are actually 12 lines, the A and B sides of this tube are perfectly balanced. Their rise time matches, their output, and all aspects of each side match.

Simple current, Mu, TC, or simple tube tester “number” matching is better than nothing, but only curve trace matching will yield this type of result.

## **Why do two Marshalls or two Fenders, of the same model, and even year, sound different – and more on matching of phase inverters, balanced output sections, global feedback, and more**

Why do two of the same amp sound different? For one thing, there was a +/- 20% or more variance in components used, but a more common follows.

I originally wrote this with a subject of dead spots in your sound or tone that people felt were due to dead spots in their guitar (or bass) neck. In the last few months while blueprinting amplifiers, I have had to explain over and over about a mis-matched output section and its impact to many. I thought it would be a good idea to get these thoughts down on paper.

In most class A/B amplifiers, there is an NFB (negative feedback loop). This is usually labeled as the PRESENCE control). Any disparity between the upper part of the sine wave (produced by half of the output tubes), and the lower part of the sine wave (produced by the other half of the output tubes), is canceled out by the NFB circuit by design. This is the reason some notes "sing" when your amp is pushed in the output section (rather than pushing the input in a master volume amp), and other notes do not have the same magic.

Since few tubes are even close to identical, this cancellation is always ongoing. The object is to limit this as much as possible.

**The most common way people match an output section, is to use good quality matched tubes.** The industrial spec for a match can be as high as +/- 20%. A good match by a lot of tube vendors is +/- 10%. I believe that even the untrained ear can hear the difference when a output section matched within +/- 5% is used. In the amps I set up for the folks that retain me, my spec is less than 2.5%.

**The most overlooked and misunderstood part of the output section is the 12AX7/ECC83 (Marshall style) or 12AT7 (Fender style in vintage cases) Phase Inverter tube.** This is the tube that drives the output tubes. A lot of folks that specialize in making amps sound great don't understand this, but fix this accidentally. They tend to use very good tubes, such as JAN spec 5751's etc., where the match is closer, and closer matched tubes in the output section. They also use tubes that sound good in the first gain stage positions, rather than the common Sovtek WA tubes which most manufacturers use (because they are sturdy, not as expensive, and ship well without developing microphonics).

When I scope an amp in the lower frequency region, the vast majority of the time, the upper and lower parts of the sine wave are not equal. This is more "off" than just a slightly mismatched set of output tubes. At this point, I install a matched phase inverter / driver.

The problem with phase inverters, is finding a matched tube. You have to remember that a 12AX7 / 12AT7 etc., is NOT a single function tube as an output tube. It is TWO tubes (two triodes), sharing a single bottle.

VERY FEW TUBE COMPANIES MATCH THE A AND B SIDES OF PREAMP TUBES. They warrant the tubes to work, and warrant them not to be microphonic, but do not say they are matched. This is not any bad commentary on tube suppliers. This is very expensive, and not deemed as cost effective to some. In the high end hi-fi and audio industry, matched triodes are a basic requirement, even if "low-fi" guitar and bass amp players think this is not necessary. Matching is time consuming and requires specialized equipment. If you can find

somebody that has a Tektronix tube curve tracer, and bring them a bunch of tubes, maybe you will be lucky and find a match. Watford Valves in the UK calls these tubes "balanced valves". Groove Tubes sells these as their "MPI" tubes and they are also spec'd for rise time and compression on a Vacuum Tube Curve Tracer in addition to matching output and the rise time. These are what I use for my clients, as it is one thing to hit both side of the output section with the same "push", but to me it is also important that the "push" comes at the same time.

Matched phase inverters and output tubes are one of the reasons some amps "sing" and others are pedestrian compared to their brothers and sisters.

If you seem to have a lot of dead spots, try a new phase inverter tube. This is usually the preamp tube that is the closest to your output tubes. It is a trial and error process, but you may get lucky. If you want to save a bit of time, these trace matched phase inverters are available from Groove Tubes from the Special Applications Group in a 12AT7 and 12AX7 version. There are not many of these in stock at any given time, so you may have to wait a bit. I am the one that makes these up, when I came to GT part time, I was asked to start and head the SAG as part of my duties. In any case, the SAG also does custom work on request, sort of "blueprinting" by phone in a manner of speaking.

Information on SAG can be seen on the GT website at the link: [http://www.groovetubes.com/product.cfm?Product\\_ID=1773](http://www.groovetubes.com/product.cfm?Product_ID=1773)

The Matched Phase Inverters from SAG are at:

SAG-AT7-MPI [http://www.groovetubes.com/product.cfm?Product\\_ID=1722](http://www.groovetubes.com/product.cfm?Product_ID=1722)

SAG-AX7-MPI [http://www.groovetubes.com/product.cfm?Product\\_ID=1723](http://www.groovetubes.com/product.cfm?Product_ID=1723)

By the way ... THIS IS EXTREMELY CRITICAL WITH DROPPED TUNINGS, 7 STRING GUITARS WHEN IN THE LOWER RANGES, AND EVEN MORE CRITICAL WITH BASS GUITARS WHEN USING TUBE AMPLIFICATION.

## On the same subject – why do Marshall and Fender amps sound different?

There are many differences that many already know, such as EL-34 output tubes versus the 6L6 output tubes. This is actually something of a minor difference when compared to some other aspects. The biggest difference, to my thinking, is the tone stack and gain stages. In a nutshell, a Marshall is about 15db higher at middle frequencies across the board, from a Fender Blackface amp.

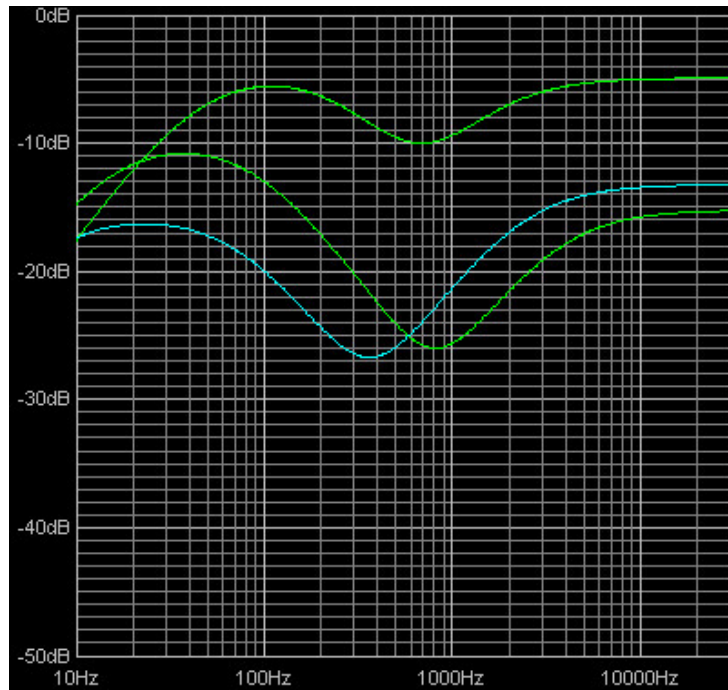

The chart to the left shows the frequency response of a Fender tone stack, a Marshall tone stack and a VOC AC-30 tone stack.

The upper most trace is the Marshall amplifier. The lower green trace is the VOX AC-30, and the lower blue trace is the Fender amplifier.

All tone controls were set to "5", or the mid point.

This does not take into account the speaker or the power amplifier section. This is just the pre-amp section. As you can see, the Marshall has quite a bit of "gain" in comparison to the other two in this "mid" state.

The figure below is a similar trace, controls set to mid point again, but with some reference information related to the guitar as far as what frequencies are in which ranges.

Remember that these three tone stacks are used in 95% of the world's guitar and bass amplifiers.



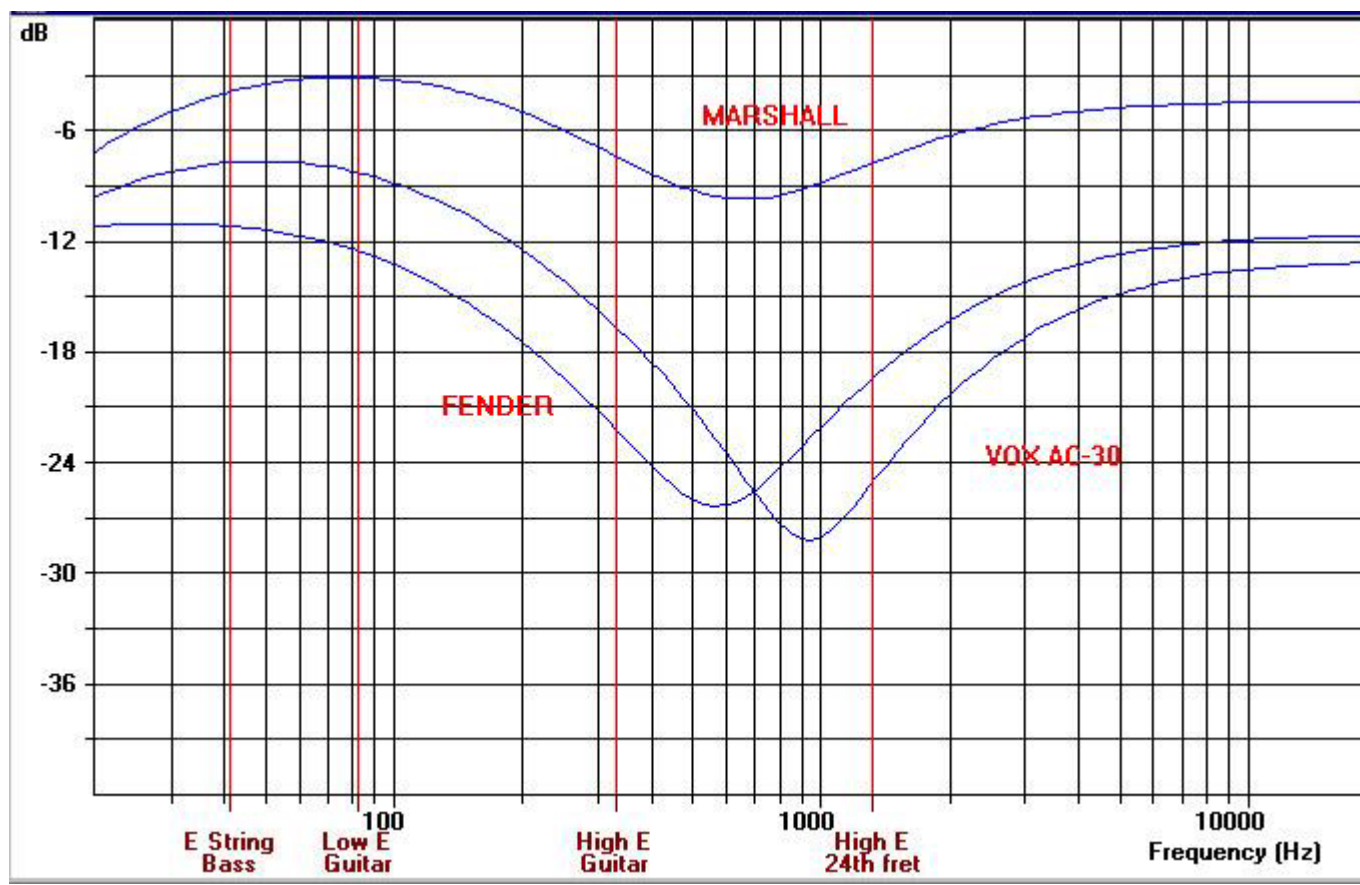

Keep in mind that as gain is raised, frequency response in many amps is narrowed. There will also be more background noise in high front end gain amps. If a circuit is more complex, there will also be more noise in most cases, and less player touch sensitivity or dynamics. This is easily seen, felt, and heard by playing a moderate level passage using a Mesa Boogie Dual Rectifier turned about ½ way up in level, and then the same passage at the same level using a Fender Tweed Twin or Tweed Bassman. It is not by chance that the Tweed Bassman is considered by many to have perhaps the finest guitar amp tone of most any amp.

Some circuit examples are noted below. Look at where the tone controls are placed. Some call this *pre or post distortion*, others call some of these a cathode follower tone circuit. In a Fender Blackface amp, the tone controls are between V1A and V1B. In a Marshall amp, there are additional gain stages before the tone controls.



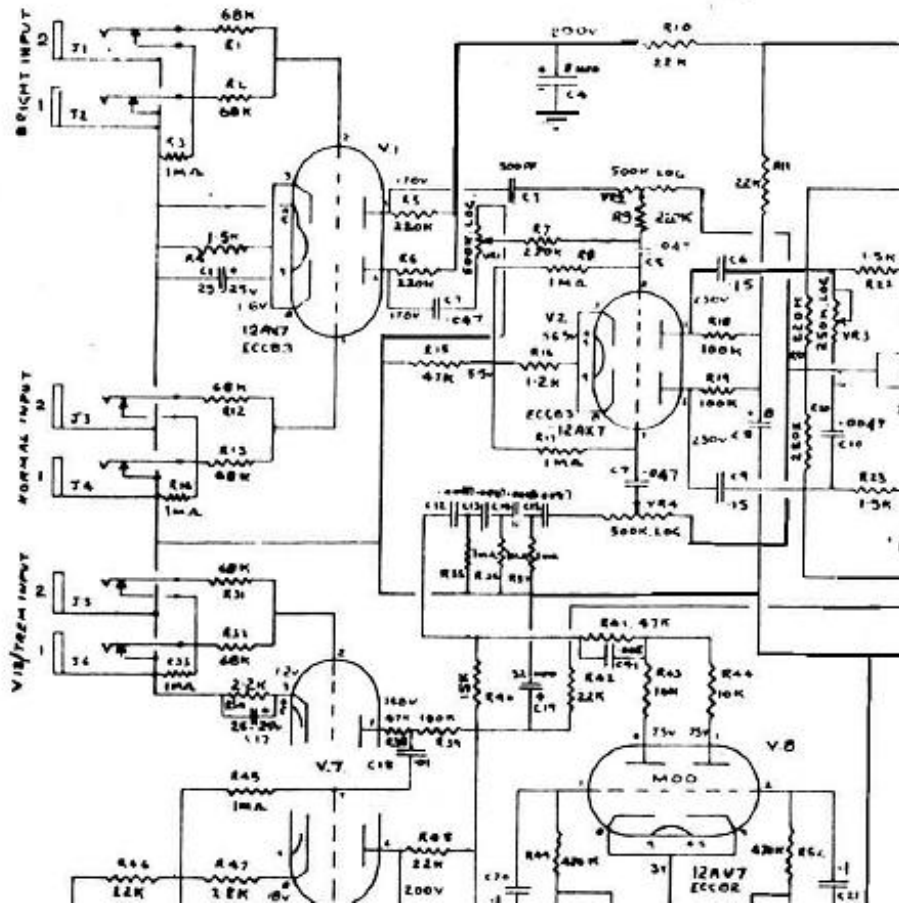

For those wondering, and want to try their eyes out on this blurry picture, this is one version of the Vox AC-30.

Most know this version as being the most popular, the AC-30/6 model. This amp actually had less gain than the AC-30/4.

Brian May of Queen was an 30/4 user rather than a 30/6 user. These two amps sound and play very differently.

## **Preamp Tubes - Gain / Output and Matching – more information**

I have written other papers on each of these subjects, and questions and comments come up where additional explanation has been helpful for a lot of folks.

The first basic point to remember here, is that unlike a power tube such as a 6L6, EL-84, EL-34, 6550, and others, a preamp tube is a "dual triode" in most cases. This includes tubes such as a 12AX7, ECC83, 7025, 12AT7 and others.

In regard to matching of two sides of a preamp, many folks feel that in a balanced circuit which in a way, "sums" the two sides of the tube, that balancing is not necessary. The high end audio industry recognizes the need for a balanced phase inverter or drivers, unlike some in the musical instrument industry.

This is necessary (the balance of two sides of a triode). I will use an example to try to illustrate. Taking a twin engine airplane, let's say we have a typical light twin with two 300 HP engines designed to cruise a 250 knots. We have each engine at 1800 rpm. One engine is at 24" of manifold pressure, while the other is at 22" of MP. The airplane structure itself, is the "balance", much like the balanced circuit that some amp builders feel will negate the need for a balanced phase inverter. The plane may fly just fine, but we need to add a bit of rudder trim, and our fuel use will be higher, and overall performance and balance of the airplane (or amp) will suffer.

Now in the "art" of balancing a dual triode, there are many folks that will perform "matching" for a few dollars of additional cost. In almost all cases, this "match" is a gain match, or a current match, or a transconductance match. Due to very high inconsistencies in today's preamp tubes, matching for any of these factors, is an improvement over an unknown tube. This sort of matching at least makes sure that we do not have a 200 HP engine on one side of our airplane and a 400 HP engine on the other side. These numbers seem like wide examples? Not in the least. A typical new preamp tube these days at a given bias and voltage, in the 12AX7 family, will run from ½ a milliamp to three times that. Their typical average is about 70% of what is expected as standard spec by the way.

Now, in our airplane example, our horsepower may be way off with two different HP engines in the stock amp, and with the easiest form of balance as above, at least our HP is the same, which is of help. But, we still have the factor that one of the engines is running at a different RPM or Manifold Pressure. This is the "time" component that is missed in most matching. You can balance the circuit all you want, from an amp designer's standpoint, to compensate for voltages or current, but you cannot balance the time component, all one can do is average the current or gain factors, not the time factor.

A true balanced dual triode, is just like two output tubes. We want their characteristics balanced in many aspects. This is why we do not plug in one EL-34 and one 6L6, even though this would work, and make some sound come out of the amp. In fact, in this example, these two totally different tubes would be closer in characteristics than the typical new dual triode of today in many cases.

What is required here is to select for output, and TIME. This can only be done on very sophisticated equipment such as a vacuum tube curve tracer. The two curves, at all voltages of operation, and with a signal applied to the tube, are compared and sought to be as close to identical as can be achieved. This is very costly as it is very time consuming. At times, only 1 in 50 tubes will make the grade. Remember, it is THIS little tube that drives your final output stage.

The folks in the high end audio industry know the difference in balanced or matched inverters, and many amp makers do also. There are still a lot of "amp" folks out there that want to fight the points here, mostly because they have not taken the time component into their thinking. If they have tried "matched" phase inverters from simple sources with simple current match methods, this may be one reason that there was not as much difference as they had expected.

The Special Applications Group (SAG) at GT was formed specifically to address issues such as vacuum tube development, testing of factory samples and production, and unique products. The SAG-AX7-MPI and SAG-AT7-MPI are just two of their products for the audio industry.

## **Part 2 - Gain Versus Output in preamp tubes**

Think of your days back in science class, where you built or saw one of those big ball devices that created a half a million volts, made a great light show, and you could touch it, and have the classes hair stand on end! Gain in a guitar amp is much the same. You can have a 20 watt amp with high gain, and shred all day long, just as "gainy" as a 100 watt monster. It is the wattage, or output, that differ, and what that "power" brings to the stage.

Today's 12AX7's as an example, all have about the same gain, which in this case should be about 100. Most today fall below this, in the range of maybe the mid 80's, with some samples going up to maybe 110. The big difference in tubes though is current output. A typical 12AX7 is expected to put out 1.2 milliamps at a given test voltage. Today's tubes in general, put out as little as ½ of that in 80% of the cases. A tube at 0.8 milliamps has a full 30% less output than what is expected. This is like a 50 watt amp putting out 30 or so watts. Some tubes are better than others from various manufacturers. Some examples of this are tubes like the widely used, and perhaps the most popular are the Sovtek 12AX7WA. This is a sturdy tube, generally free of microphonics, with acceptable gain. Part of the reason they are quiet, is they tend to be lower in gain than many other 12AX7's, but are also much lower on output current. It is much the same as with power tubes; where in the same amp, one duet of output tubes will put out 50 watts, while another set only 45 watts. Thus, the Sovtek 12AX7WA, is quiet, due to lack of output and gain in many amp circuits. These tubes are sturdy and inexpensive, and help a lot of amps make it through the warranty period. On the other side of the coin are the JJ ECC83 tube. This is a part of the 12AX7 family, but different construction, plate materials, cathode coatings, and other factors give this tube a bit more gain than most others. This can be 100-120 Mu, rather than the 85 or so of a 12AX7WA Sovtek. The big difference in the ECC83 in general though, is it's current output, as times over 1.5 milliamps, or in some cases, three times MORE than a Sovtek12AX7WA.

Like I have said in the past, preamp tubes are a crapshoot. You buy your tubes and take your chances. Some folks like Groove Tubes, screen and test for microphonics, noise, AND low output. The ones that do not pass all tests are rejected, in some cases, over 50% of the factory run. There is still a range of specs even in these more rigidly tested tubes, but the spread is much tighter. In any of these cases, the end user still does not know what the tube is actually doing. The SAG area at GT takes tubes, and runs them through another process, where all the specs are recorded and traces are performed. These traces show rise time, and other factors. Like the SAG-MPI's, there are other "kits" such as the MHG (Marshall High Gain) kits, which can be used in any 12AX7 based amp, not just Marshalls. I guess I should have called this a High Power kit, which would have been more accurate actually. There are Fender High Gain Kits, and Fender Soft Touch Kits, and the SAG generally tailors preamp tubes for specific uses and tastes.

In any case, don't confuse gain and output. They are very different qualities in a tube.

## **Power / wattage – how much do you really need?**

The vast majority of the time when I first walk into a venue where I will be listening to music for the night, I can generally tell if the performance will be a memorable one. I can generally tell from the equipment setup, and not to brag, I have about a 90% track record.

The 10% of the time I am mistaken, it is generally easy to explain. I did not know the performer or group, and what to expect. I was invited as a guest, and the music was already known to me as to not be of my particular taste, or a few other reasons.

The big tip off, is amplifier compliment – amplifier power that is.

There are folks that have blinding fast technique. Speed metal players, fast articulate players, folks with speed as their underlying goal. Frankly, this is not my personal taste. I am generally impressed for ten minutes, but then my attention is lost. I generally ask myself, are these folks practicing, or just looking for the right note? One note played with feeling and that has tone, is worth 100 64th note triplets from my point of taste. But, this is personal preference, and I have a lot of clients that are speed metal masters, that have the ability to play most anything they want, much better than I can play my own preferred style. These folks have unique requirements, and generally a lot of power is wanted, for reserve clean headroom. Most of their sound and tone comes from front end effects and/or pedals.

The biggest problem form most cases, is amplifier power. When I see a 100 watt amp on the stage of a 150 seat venue, I know that I am in for trouble ... most of the time. If it is a jazz player looking for a clean sound, then I am safe. If it is a speed player, well, then it is what I expect. If it is a rock or blues band, then I know I am in for a very one dimensional performance most of the time. I know with good prospects, a few other things. The player does not understand amps or tone, perhaps his main rig is broken and this 100+ watt amp was borrowed, or they are into a hi-fi sort of sound with little or no dynamics.

A 100 watt amp, or even a 50 watt amp, will not distort in it's output section at rational volume levels. Folks that are known for great tone and to be great players, even in the largest venues, generally stay at around 50 watts or less. They are looking for a particular sound, tone and feel. They let the stadium sound systems do the rest. If you cannot turn your amp, and most amps, to at least 6 or so on the volume, you will never tap the soul of most tube amps.

Folks also do not understand "loudness". Many think a 100 watt amp is TWICE as loud as a 50 watt amp. This is not all the case. Double your wattage, and all you gain is 3db. Sure, folks talk about "headroom", and think this is a huge requirement. Folks that actually need headroom are clean players ... rhythm players, jazz players for some styles, and pedal steel players to name a few. A amp with a lot of headroom is a hi-fi amp. It will be clean, and not have the dimension of touch dynamics of a lower powered amp. If you want more loudness out of a 50 watt amp, double your speaker area, or go with a more efficient speaker. Going from a 83db speaker to an 88db speaker, is almost the same gain in volume as going from 50 watts to 200 watts in amp power.

There are folks that have the great idea of pulling two tubes out of their 100 watt amp to turn it into a 50 watt amp. To put it bluntly and open myself up to a log of flack - this is a stupid idea. A great amp is made up of many components. Power transformers, output transformers, capacitors, and other parts, make up the design. If one takes a Marshall 100 watt Super Lead, and pulls two of the tubes, and properly sets the impedance selector, turning the amp into a 50 watt amp, what actually happens? Well, we have a 100 watt power supply, which is now even less taxed than before. The "50 watt" Marshall will now have less dynamics, less feel, less touch sensitivity. It will be a nice, clean, hi-fi, 50 watt amp. It's 100 watt power supply will never reach saturation. It's output transformer will never be pushed. It will actually be cleaner than it was as a 100 watt amp. The only distortion you will get is when the output tubes are at their limit, and this will be an unbalanced sound, although some might think this is just to their own tastes.

## **Modeling amps?**

In the past, I have written a lot on solid state amps versus tube amps, and modeling amps versus the amp originals they are modeling. Modeling amps have some strong points such as a lot of sounds for the dollar or in a given space, or for recording. Some think in a live venue, modeling amps can have limitations. To my way of thinking, this live aspect is sort of a "yes and no" to me, just as with any amp, tube, SS, or modeling amp. I see many folks with 50 watt amps in small clubs, where the soul of the amp is never tapped. Put an amp like a Line 6 Vetta, Fender Cyber Deluxe or Cyber Twin, or Vox modeling amp out there, and you may be surprised. These amps may be just the ticket in any size venue, and in small venues where maximum overdrive is sought at rational levels, may be a super option. Recently on a five day cruise with my family, there was one of the entertainers who covered just about every music style that was ever done, solo. He had a small rack with a Panasonic laptop. This held his song list, and was on a music stand close at hand. It had a sound card of some sort, and internal drum machine, sequencer, and midi outs to a small synth rack. This was all fed into a stereo SS rig, used for PA speakers, and just there for clean sound. His Guitar amp was a Line 6 Vetta. He was a hit on the ship, and had more folks in one bar area, than most of the "conventional" bands on the ship. He was a fun act to see. His rig was light, portable, and very versatile. In some cases, a modeling amp may be the ONLY proper choice. Reflecting back on what I wrote on that cruise incident when I first produced this document, I have had additional thoughts brought on by questions from many folks. This was my response to one forum post on the subject which I wrote:

*There are some places where tube amps are totally unacceptable. Recently I was on a ocean cruise with my kids. The crew on these ships work seven days a week for at least a six month tour. Same for the entertainers. The ship gets back on a Friday morning, and leaves late that afternoon. No time to take an amp to a tech as one part of the situation.*

*Add to this, the players may be playing for the show in the big showroom one night, rock in a club the next, and jazz the next night. The amps are moved all over the place, and having an amp that does a number of things rather than excel at one thing, is really a prime consideration.*

*In this case, something like a Vetta, or even the Spyder, would be a killer amp to have. A Super Reverb, Mesa, or Marshall would be about the worst thing one could have.*

*It boils down to the right tool for the job.*

*I heard a few modeling amps on the cruise, and frankly, they were killer. The worst amp I heard was a tweed Fender Bass Breaker, whose tubes were shot, bias was off, and had at least one noisy and microphonic tube in the first gain stage. I was so bad I had to leave that rock lounge called something like China Town on Carnival to Ensenada (over Christmas) if anybody else that reads this was there.*

*Thank the tone gods for a fellow with a smaller Marshall Valvestate and another fellow in a Reggae band with a Line 6 Axis. They sounded great, and the guests loved them.*

I personally prefer the PROPER wattage tube amp as first choice, but I will take the modeling amp every time over the wrong tube amp. Why? Modeling amps allow a degree of touch dynamics and tonal ranges to be captured at most any level. You have all sorts of controls for this ability. A Fender Tweed Bassman in a small venue will never be able to be cranked to it's level of tone potential for some music styles. A Line 6 Vetta may pull off the "tweed sound" of the virtual Bassman in a much more convincing and pleasing manner, at least to my tastes.

I think to end this, all I can suggest is, listen to amps, and play them. See how they react to your touch. If this is not a part of your music and style, such as many folks that start the song at 110db and end it at 100db, then most any amp will work pretty well. As you develop an ear for different tone aspects, and fingers and touch that can give you at least two more playing dimensions, then you will move to the next step of being a better player, and also have a more heightened ability as a listener.



## Fender Blackface Tube use and application

Preamp Tube Layout for Fender 2 Channel Amps

Fender 2 channel reverb amp preamp tube layout (as seen from the back of the amp)

Tube Designation V6 V5 V4 V3 V2 V1

The power tubes will be to the left, and in some 50 watt amps, there may be a tube rectifier (amps such as the Super Reverb and Vibrolux are examples of amps that use a tube rectifier). The Bassman and Bandmaster of this era use solid state rectification.

Type-->	12AT7 V6	12AX7 V5	7025/12AX7/A V4	12AT7 V3	7025/12AX7A V2	7025/12AX7A V1
	Phase Inverter	Tremolo	2nd gain stage for channel 2 and reverb return	Reverb driver	First gain stage for channel 2 (Vibrato)	First gain stage for channel 1 (Normal)

Typical examples: Deluxe Reverb, Vibrolux Reverb, Super Reverb, Twin Reverb, Showman Reverb, Dual Showman Reverb.

### V1

If you don't use channel 1, you can remove this tube. Doing so will give you an increase in gain in channel 2. Keep in mind that channel 1 does not go through the reverb or trem circuit, so may give you another tone variation. Also note that for each channel, input 1 is a higher gain input than input 2. Input 2 will generally yield more clean headroom. This is one location where you want a very high quality tubes that has proper gain, proper output, and is NOT microphonic or noisy. Any noise or problems here will be amplified down the remainder of the signal path.

### V2

This tube is critical for the best tone for channel 2 (your reverb/tremolo channel). This is the channel most folks use on these amps. Many of my clients use a 5751 in V2, and this will give less front end gain, more clean headroom, and a higher percentage of output tube distortion versus preamp tube distortion. This was an old SRV trick. A 12AX7C, ECC83, 7025 long smooth plate, 12AX7R2, and 12AX7R will all sound very different here. Don't expect all "12AX7 or 7025" tubes to sound or play the same. They do not.

### V3

This can be a critical position, and noise here will be an issue down the signal path if a good tube is not used in many amps. Some 12AT7s that will work just fine as phase inverters (V6) will be noisy and pop when used in this position.

V4

The 2nd most important position which will impact the tone of channel 2 as this is a part of this channel's signal path. The "help" to us here, is that this is not as high of a gain position as V2, so a tube that was microphonic in V2 may work well here.

V5

This is the least critical tube position in your amp. This is used as an oscillator for the tremolo circuit and has little effect on tone to some folks thinking. To my thinking, you still want a decent tube here, as you can see, that if you pull this tube, the amp will not play at all, so at least some aspect of the signal path from the Vibrato Channel (channel 2), is using this tube. This tube is basically a current driver, rather than part of the gain and tone stage, so this would not be a position for a very expensive NOS tube as an example. But, I would never toss a junk tube, noisy tube, or weak tube in any amp position.

V6

Your phase inverter should always be replaced when replacing power tubes. I feel this should be a dynamically balanced phase inverter, as explained elsewhere in this document in great detail.

### **..... From Mark Baier at Victoria Amplifier**

As an added treat, I will include some additional NOS data for those interested. This was written by Mark Baier of Victoria Amplifier Company (<http://www.victoriaamp.com>). Mark is known as something of a "tone god", and is also on the advisory board of Tone Quest (<http://www.tonequest.com>). I have a fairly large Victoria area on my own website that has additional information and photos on many Victoria amps at <http://www.guitaramplifierblueprinting.com/Victoria1.html>

### **Thoughts on 12AX7 type tubes by Mark Baier**

Keep in mind that he wrote this back in 1998, and a lot has changed since then on some fronts. Mark is generally pretty darn busy building amps, and I am generally pretty busy testing each new factory batch of tubes that comes out. For the latest 12AX7 information you can click here ... or .... for information on preamp tubes in general and matched phase inverters click here. (Myles comment here)

Howdy folks, I'm back with more wisdom for the ages for ya. As I sit here in front of my keyboard trying to conjure up something semi-literate to say, I must confess to having a new appreciation for writers and daily journalists...I suppose it helps to have at least SOME idea of what to write about...How about the vacuum tubes used in guitar amps??? Kind of a no brainier type of subject given what this page is dedicated to...N'est pas??

I'm always a bit surprised by how little the average guitar plinker knows about the glass bottles that power their amps. Sure, much has been written by self proclaimed gurus as to the physics of vacuum tubes, or how to turn a BF Twin into a '51 Super, but how much discussion is ever given to the SONIC differences between a GE and Sovtek 12AX7? I'm gonna invent new and exciting sonic adjectives

for the occasion! You'll want to rip your hair out trying to decipher what "chewy and refined with a touch of lacy brilliance" actually means!! When I'm done writing this, I'm gonna compose my monthly article for Wine Spectator...

At this point it's probably a good idea to note that I did not conduct an extensive, dedicated listening test using a specific model amp and guitar. These opinions are based on years of playing many guitars and amps of various manufacturers and vintages..The focus of this assessment will be with a '50's Fender Tweed type amp in mind. Aside from being my favorite kind of amp to play tone wise, they make a good platform for evaluating tubes due to their simple circuit topologies.

#### Preamp Tubes:

GE 12AX7: Most commonly available as JAN type/mid '80's vintage. Has a soft top end-not edgy or piercing. Nice solid mids and lows. Lots of depth and texture to the tone. Older orange box versions seem to be a bit more brilliant. Can be a noisy tube, this would be a problem for high gain amps. Can sound grainy in some amps. Moderate amount of gain. Good NOS American tone...for years these were standard issue in your Fender amp. If you're using the recent JAN stuff, pack some spares; these were an end run situation, QC was a bit slack. Standard Phase inverter tube in a new Victoria.

ECG 12AX7: Like the GE mentioned above, this tube is most commonly found as JAN examples. With the wild west capitalism that is the rule in the tube biz these days, these JAN stocks are the most reliable source of actual NOS US and British tubes. These tubes are visually identical to the '60's and '70's Sylvania's. Like a vintage Sylvania, they display a lot of gain and midrange/top end brilliance. They sound great in a cathode follower stage. Real creamy when driven. A preamp tube that can cut through the mix. Not as textured as an '60's RCA, but possessing a more authoritative body. Can be a problem tube; prone to microphonic behavior and fizzy static that comes and goes at will.. A nice vocal tube that will color a soundstage with its usage. We use them as a standard tube in our 3X10 & 4X10 amps to give some bite to the darker Mojo 10" Alnico speakers we use.

RCA 12AX7/7025: Through the years, RCA produced a few different types of 12AX7's. Typical late 50's types would have a large ribbed plate that is dark gray/black in color. Branded 12AX7 and 12AX7A. This vintage is rich and appealing sounding with a very musical midrange bloom. Round, warm bass with a compelling, lacy top end (don't say I didn't warn you). Very similar in construction and tone to contemporaneous Tung-Sols. Existing examples are increasingly rare and unpredictable in performance. Can be a noisy tube. You know that 'noise' test point on your TV-7/DU?? It was put there because of this tube. Expect to screen this tube before using; average samples will frustrate you with uneven performance. Early-mid '60's-'70's examples of the RCA 12AX7 are my favorite in this family of tubes. They have a shorter ribbed plate structure and the actual plate is lighter in color. Very broad, even response. No frequency group is accentuated..everything sounds even and in perfect harmony. Most true NOS examples exhibit goodly amounts of gain though not as forward as Sylvania's. Particularly fine with Fender guitars. Bouncy and expressive. Perhaps the best sounding hi-fi tube around, right up there with Telefukens, expect to pay up for real, tested, NOS examples. I dearly love these in our 80212's. They tickle the ceramic magnet 12's we use beautifully. 7025 versions are screened, tested versions that were specified by many manufacturers because of their low noise, audio intention. Physical characteristics of this tube are virtually identical to the classic Mullard type. I've seen Mullard, Brimar, Amperex and GEC's that appear to be identical to the RCA 7025. Most European examples have a seam at the top of the envelope. Performance is interchangeable as well. I suspect that the lauded Mullard "M" series of tubes are hyper tested examples of this classic RCA structural platform.

Telefunken ECC83/12AX7: Known through 2 versions, ribbed and flat plate. Has achieved mythical status, certainly perceived as the benchmark 12AX7 by hi fi nuts, and with good reason. Even scope pulls can test way above minimum and still sound terrific..It's not unreasonable for this tube to last for more than 100,000 hours!! Lots of OOOph when used in a guitar amp...rich and 3 dimensionally complex. Note decay is very musically textured and fine..Breaks up with an encompassing, balanced presentation. Transparent sounding, giving a broad, even response. Richly toned without sounding muggy. Lots of air and space, a delicate authority is achieved. Very commonly found in old hi-fi sets and industrial test gear. Not as common in American guitar amps like Fender, but seen quite often in off brands like Guild and Silvertone. Often rebranded with the amp manufacturers name. These work great in higher gain amps like Marshall where noise would preclude the use of a more "colorful" tube.

EI ECC83/12AX7: A new Eastern European type currently being produced in Serbia. This tube shows lots of promise. Extremely similar to the Telefunken in construction. Can be discerned by the seam on the top of the envelope; the Tele doesn't have this. Sonically, a bit more colorful than the Tele. Can be edgy and harsh sounding. very forward midrange. Terrific tube in higher gain rock amps like a Matchless. Must be carefully selected for noise and microphonics. Aggressive sounding with a definite bite. Not a subtle, refined tube. Expect to reject 50% for noisy operation. Not as musical as a GE or RCA, but still very good. Many are being rebranded by fast-buck hustlers as Telefunken..watch it.

Sovtek 12AX7: Available in a number of versions. Early types are 12AX7WA and WB. Recent examples labeled WXT and WXT+. Higher distortion and gain than RCA and Mullard types. This characteristic endears them to users looking for a distorted, aggressive attack. Not as quiet as the Chinese 12AX7, but possessing a lower noise floor than common US made GE and ECG types. Very reliable long lasting tube. Lacks real voice and character when utilized in old style Fender Tweed and BF era amps. Somewhat lifeless and flat sounding in amps where tube disposition can be discerned. Great tube for amps that derive their tones through circuitry manipulation, i.e. multi-stage cascading gain amps, built in effects amps, "lead" amps with buttons and knobs that say things like 'pull thick', 'drive', 'solo' and 'thrash'.. Not microphonic or particularly noisy. Really a plug it in and forget about it tube..Good for guys and gals who don't want to be bothered by fiddling around endlessly with their tubes...

Shuguang 12AX7: Chinese made, current production in limbo. Last batch reputedly made in mid 1997. Very quiet, well made 12AX7. Reputedly made using Mullard or MOV equipment. Rich toned, if a bit lacking in low end and mids. Nice sense of space and air around notes. Fairly high gain, good for modern amps. Low noise floor good for critical high gain applications. Downside to this tube is its longevity. These things wear out quickly, getting smudgy and flat; as if someone threw a blanket over the tone. Easily recognizable by the shiny metal stiffeners between plate structures. Always house branded, common guitar brands include Mesa, GT, Fender, and many others. Designer versions can get pricy. Recent versions of this tube include a shiny plate type dubbed a 7025. Some folks really swear by this variant. If cathode is the same as other Chinese versions, it's gonna have the same longevity problems. More musical than the Sovtek, but not as compelling and textured as a NOS GE or RCA. Very common as recent Fender and Mesa OEM type.

GE 5751: Originally a 12AX7 with beefed up internal elements for operation in action man military and industrial applications. Five star versions are highly prized for their careful parameter control. Most examples in stock these days are the JAN stuff from the mid '80's. Very good side to side matching. Very tubey sounding tube. If you're trying soften up a harsh modern amps, this may be the "go to" tube. Don't over use it; too many 5751's in the tone zone will deaden things. Less presence and air to the top end. Nice and clear sounding--kind of a soft brilliance. I like them best as input amplifiers replacing the 12AY7 called for in '50's Fenders.

ECG 5751: I don't have a lot of experience with this one..I would expect a greater reject rate than the GE's based on my experience with all the ECG stuff.

RCA 5751: A very nice tube--very hard to find. Be careful these days when purchasing NOS examples. I suspect that RCA didn't make a whole lot of these, consequently, you risk buying used stuff unless you know what you're doing. When you do find them, you'll be treated to a rich, full sounding tube that's detailed and 3 dimensional. Very musical. The GE sounds thinner when compared directly..the RCA has more body and depth.

This list hardly represents a complete assessment of every preamp tube available, but is intended to address to sonic characters of the most commonly found types. The basic structural platforms are the GE, ECG/Sylvania, RCA (two types), Telefunken, Reflector(Sovtek), and Shuguang. The 12AX7 type tubes available today will no doubt be an example of one of these. I hope my impressions of the differences will be of value to you and enlighten you to the tonal manipulation possible with this benchmark tube type.

## **Blueprinting amplifiers – What is “blueprinting” ?**

"Blueprinting" sets up and tunes an amplifier much in the same way as blueprinting the engine and suspension for a car. Using proprietary methods, we match the amplifier to the guitarist or bass player, for his particular playing style.

A guitar amplifier can be compared in some ways, to a production automobile. When it comes off the assembly line, it must meet basic requirements which are within a broad range of specifications. An amplifier can be "tuned", much in the same way that a race car is set up for a certain driver on a certain track ... suspension, engine tuning, etc.

We do not "hot rod" an amplifier, that is not the purpose here. The amplifier is specifically set up for a particular guitar player's style and musical tastes.

The best amplifier manufacturers in the world, even if they had the time, cannot set up an amplifier in this manner. There is no direct contact between the player and the manufacturer in most cases. Sometimes you will hear of amp builders that do this, such as Dumble, but in most cases, this is not the norm.

Amplifiers are also shipped with various styles and brands of tubes. An amplifier using 6L6 style tubes, may be shipped with Sovtek, Svetlana, Tesla, or others. Each are very different in sound. A "6L6" amp may use 5881, 6L6B, 6L6C, KT-66, tubes also... all different. During the process, we may swap tubes many times, working with the client to capture his "sound". Preamp tubes are especially critical in this area.

After the tube types are chosen, we move on to the second objective in this area; matching the output section of the amplifier.

Mis-matched tubes work against each other. Your notes will not "sing". Some notes will die a quick death of decay. Sustain is reduced dramatically and even absent at some frequencies. It is very important in a class A/B design, to have a close match in the output section. Any difference in waveform will be canceled out in the NFB loop as used in Marshall and Fender style amplifiers.

Many times a player will have some notes "sing" and others sound lifeless. They usually explain to me, that it is "a dead spot in the neck" of their particular guitar. At this point, I have them try another guitar, if available, of the same type. About 90% of the time, they are surprised. The other guitar shows the same "dead spots" on the same notes. It is not the guitar ... it is the amp. I also show them why this is happening on a scope with a signal generator. This is one of the reasons that the player must be present when we go through this process for the first time. This is not a procedure where you can drop off your amp and pick it up a few weeks later.

Another common source of these "dead spots", is an imbalanced 12AT7 or 12AX7 phase inverter or driver. Very few people match the two sides of a preamp triode. Some of the vendors selected to be shown in our tube vendor section can do this.

When it comes to preamp tubes, most vendors check that the tube "works". They will also sometimes check that it is not microphonic. That's usually the end of the story. It is not practical to expect that any tube seller would match the two sides of a dual triode as a general practice. This is time consuming, and requires specialized equipment. It involves going through a LOT of tubes and FINDING the pick of the batches. You cannot make matched triodes, you have to find them. This would easily double the cost of existing preamp tubes from suppliers. Some folks that sell tubes for high end audio and hi-fi applications will perform this matching at additional cost. The cost is money well spent. Less than 5% of preamp tubes are matched within the range we use for our phase inverters. Typically on a good day you will find 1 in 20 ... on an average day it can be 1 in 50.

A mismatched output section - If one puts the amp on the scope with a lower frequency input waveform, it is easy to see the non-linear waveform between the upper and lower sides of the sine wave. Even the most non-technically involved person can "SEE" the problem as well as hear the problem. This test is done during the blueprinting process. THIS IS EXTREMELY CRITICAL FOR GUITARS USING DROPPED TUNINGS OR 7 STRING GUITARS WHICH TAX THE LOWER FREQUENCIES.

The first stage of gain, or the first preamp tube (usually called V1), is a very important and tube in your amplifier. It sets the initial gain, tonal qualities, and noise floor for the amplifier. If you follow the link in the tube reviews to the 12AX7 section, there is a technical paper on this subject, along with some tips and hints.

Bias has a great impact on the way an amplifier sounds, distorts, and compresses. Most amps are set to a specific value as the norm. If one sets bias in a conventional manner, the amp will generally have good tube life overall, and work fairly well.

Bias can be set to other values, which can change sound and feel. It will also change power, tube life, and where the amps output section starts to distort. Amps that have a grainy character as a design (such as Mesa Rectifiers), can also have their output section adjusted, even if you wish to maintain the fixed bias feature of these amps. Marshall amps with a crunch character can have this "moved" to lower or higher volume ranges in the amp. In a class A amplifier, there are other methods of producing the same results and even fixed bias amps such as these have tricks that can be done.

Once we know what you want, what you like, and we have made it happen ...all of this is recorded and documented. This makes it possible in the future to have your amp serviced if you cannot be available.

Once your amp has been blueprinted, you are one of our clients. If you are in the local area, you will be given a phone number to call for help, or be met at the studio or performing venue to fine tune or change things before a session or performance.

The service of blueprinting an amplifier generally takes about three hours, although in some cases, can take longer. Email me if you would like additional information.

Amplifier blueprinting consists of the following operations:

1. Scope the amplifier for clean output before work is started. Record output in watts.
2. Scope the amplifier for maximum output in watts before work is started. Record output.
3. Measure B+ Voltage
4. Check Bias / current draw on existing output section. Record results.
5. Record percentage of current draw of output section. Record results.
6. Check match of side A and B, and microphonics of all tubes in preamp section of amplifier. Discuss various qualities of different preamp tubes and reach a target objective.
7. Check percentage of match between sides A and B of phase inverter.
8. Have Musician play amplifier and discuss qualities they would prefer if any.
9. Install new output tubes if desired and re-bias amplifier, or if non-adjustable bias or class A, replace the current tubes with tubes of a more optimum range.
10. Work with musician changing idle dissipation as to focus in on their particular needs, style, primary guitar, etc. Adjust as required.
11. Check phase inverter and match of output section using LF waveform to check for optimum phase balance. If necessary, replace phase inverter again.
12. Measure and record the final current draw.
13. Measure and record the final percent plate dissipation.

14. Scope the amplifier for clean output. Record output in watts.

15. Scope the amplifier for maximum output in watts. Record output.

If the musician wishes, he may supply his own tubes of his preference. I will test and classify these tubes as part of the process. I am not in the "tube selling" business, and there are perhaps better avenues for tube purchasing than using me as a tube salesman. I will be happy to advise in any case.

## **Which amp is better ?**

This was in response to a forum question where somebody was asking which of two amps was "better"

Hmmmm....

Bogner or Soldano? Which is better?

Can I ask a question to help answer the question ....

You are walking down the street on a nice day. You are a single male, open to a night out with female company if the situation presents itself. As you walk down the street, coming right toward you are two girls.

One is 5'8", blonde hair, green eyes, and drop dead gorgeous.

The other is 5'4" brunette, blue eyes, and equally as much of a knockout.

As they both approach and get close enough to speak, one of them gives you a big smile and starts the opening of conversation, and starts to flirt with you in a nice way.

Do you really care at this point which one of them it was?

Just like girls .... or guys (if you're female) ... or actually girls and girls or guys and guys or .... Its a matter of what you are open to at the time and what appeals to you. Both the girls in this case are terrific, and I think both your amp examples are terrific too... its a matter of taste and timing .... how much cash do you have in your pocket when you walk into the store and one of those amps is on the floor.



## **NOS TUBES – The hype, myth, and reality**

I wrote this a while back, before working as a Groove Tubes consultant.

Are NOS tubes any better or different than the new tubes made today? Many folks cannot seem to tell the difference. After a recent batch of new tube testing, where NOS tubes are used as a standard for some areas of the test, I thought some explanation of this subject was warranted.

Why can't some folks hear and feel the difference? This is actually pretty easy to explain. A lot of today's players, especially the younger ones, have never played an amp from the Fender Tweed era. These amps had simple circuits and lower gain. Playing one of these amps yields a feel that cannot be approached in higher front end gain amps. The higher the gain, the less articulation, harmonic content, and frequency response in many cases. These vintage design amps also would sustain at low volume levels, or most any volume level.

You don't want to accept this? Try this simple test. Take your high gain amp, turn the master way down and the gain pretty far up. Hit a nice power chord, and while the chord is ringing, hit a note or two ... in a lot of amps one will barely hear the added notes. Crank the gain all the way up now. In a lot of amps, the sound has become so indistinct, that even chord changes are difficult to discern.

Vintage amps and vintage circuits have a different tone and the amp plays differently. Most of the younger generation have not had a chance to play some of these amps, if any of them. It is like making comments on how fast a Ferrari BB512 is as you watch from the curb. It is different than making the comments after sitting in the driver's seat.

So, the hype of NOS tubes? The hype is generally the comments from folks that plug a nice NOS tube in their very high gain amp and crank it up. These folks need to spend a bit of time and also learn what to listen for such as harmonic content, life in a note that is held, and body and depth in the notes. High gain front end amps with complex circuits in many cases do not show the same benefit as a cleaner design front end. This is especially true when an amp designer used a tube such as a 12AX7WA Sovtek as the foundation of their design due to cost or availability.

## **The reality of NOS**

There are many factors, but economics and law suits and liability, and the EPA are two of the today.

Liability? You bet. The money goes to safety. Cars ... airplanes, etc. This boils down to STEEL. Yup, That stuff your car body is made of, turbine blades in jet engines are made of, etc.

Steel was really coming into it's own around World War 1. Submarines needed metals that could be compressed at depth over and over. Airplanes need crankshafts that could stand up to their job. Metallurgy continued to improve. There were great steel companies such as US Steel in the USA, and the fine Swedish and Finnish steels. Today, most of the US steel companies are gone. The great controlled

steel recipes are reserved for more critical applications such as aerospace or the automotive and aircraft industries, where a lawsuit is just around the corner. If a tube fails in an amp, who cares?

The EPA makes production of cathode coatings and like items more costly and at times almost impossible. Some of the chemicals used in some aspects of production are not EPA approved. This is not that much of an issue in some ways, as once the cathode material is on the finished assembly, it is not toxic. It is easy, but more costly, to make tubes in the USA, it may just require that a batch of cathode material is produced "offshore".

Then, there is economics from a geographic point of view. The Russians are not cranking out defense equipment any more. They have no money. One batch of steel is completely different than the next batch. In Eastern Europe, it is the same when it comes to the quality control of metal alloys. There is little economic reason to have high quality control standards in a cheap vacuum tube. My original background was in Naval Architecture and Marine Engineering. Looking at tubes from 2001 and later, when doing metallurgy analysis on the plate materials, I found Monel in plate materials. In the concentrations of this metal, which is normally not found in tubes, and by certain dating of alloys from when I was in the military, it became sort of obvious .... Russian tube plate materials come from a lot of sources, and one of them seems to be the scrapping of military marine equipment. Atomic tubes anyone?

When tubes were used in scientific, medical, and defense equipment, quality was an issue. Today it is not an issue.

### **So, where does this get us?**

Today's new tubes are very inconsistent. Their specs run plus to minus 50%. They are not linear (those plate alloys react differently as the frequency changes and heat changes for one thing), and they do not meet specification that were established in 1957. They may meet one spec of many specs, but only if you are lucky in most cases.

Recently I tested some new Sovtek 12AX7LPS tubes. These brought this subject home. Using a myriad of test equipment, it was found that in one area, these tubes did beautifully. This area was simple gain. Using the Vacuum Tube Valley small tube characterizer, these tubes produced the "gain" of 100 or over a bit in some cases, just as a 12X7 should. BUT ... a tube has more than one factor.

Gain. Think of gain as horsepower. Just like cars today, some have a lot of horsepower via small displacement and turbo charging. It took a few decades to get back horsepower into cars on the road after the gas crisis of the seventies. There are big dollars in cars, and consumers wanted horsepower and performance. Over the years, even with CART standards, we got back horsepower. We got little else initially, but with all those consumer dollars at stake, by the late 1990's we also got back overall performance. By the way, in regard to gain, a 12AX7 is "supposed" to have a gain of 100. Most tubes today fall below that with an average of 85-90 at best.

Today's tubes have fair gain. They may not have linearity (drivability), but they have gain, in varying degrees.

Output. Think of this as torque. This is one thing today's tubes are lacking. Output is what pushes your signal through an ever expanding load of resistors, signal processors, effects, and tons of additional circuitry in your signal chain. Look at these three and four channel amps, where V1 (your first gain stage and the mother of your tone), is expected to drive the rest of that mess of a signal path.

You can look at that Sovtek 12AX7LPS that had a gain of 100 or 105 in some cases, out with an output of 0.5 – 0.6 millamps, it had half the expected output of a good 12AX7.

Today's tubes do not have output .... No torque.

Transconductance. Think of this as acceleration. The ability to react to a signal (or green light) and get off the line fast, slow down, speed up, and take the corners. This also relates to how linear an tubes response curves perform. With a nice linear response, note changes have the same levels. If this factor is lacking, you are fighting your instrument trying to compensate for it's non linear character. Again, the Sovtek 12AX7LPS did not perform even close to 1957 or NOS spec.

By the way, the Sovtek 12AX7LPS is a great tube by today's standards and performs better than a lot of them out there.

So, this third factor, TC or acceleration, is also missing.

### **Where does that leave us?**

NOS for one thing is a short term option. Short term? Sure, this is limited stock. The reason the 50's tubes fare better than the 60's tubes in some cases, and the 60's better than the 70's, and so on, was that in the 50's, more tubes were used for critical applications. They had better metals and QA. Many of today's NOS tubes are "pulls" or the ones left at the end of the line in a manner of speaking. The ones that have been bounced around, returned from past customers of NOS dealers as being noisy or having other problems. The percentage of great NOS tubes is getting smaller all the time, and the price is going higher as a result.

If you do want to procure NOS tubes, your best bet is a great and trusted vendor. Upscale Audio, KCA NOS, Vacuum Tube Valley, are all great folks with great reputations. If you want to buy a fair amount of NOS tubes, then you should invest in a proper tester of some sort such as the unit designed by Eric Barbour (ex. Svetlana and current Vacuum Tube Valley) and Charlie Kittleson (editor of VTV). This is a great unit and more can be seen on this unit at <http://www.vacuumtube.com/toppage31.htm>

### **There are some points of light on the horizon thankfully in regard to new tubes**

Well, thankfully, the Chinese have money and are putting it into consistency. They have the finest machine tooling in the world at times. Most of this is newly made tooling that is tight and accurate. This is a far cry from some tooling that has been around for half a century and at times not properly maintained. The Chinese see the economics of the music business as a strong market with MTV, VH1, CMT, and more amp makers than ever before in music history. Each Chinese batch of 12AX7's is better than the next. Their "torque and acceleration" are currently better and closer than any of the Europe tubes generally. Their consistency is also the highest.

The last hope lies in the hands of folks like Aspen Pittman (Groove Tubes). GT spent a LOT of money to remake a tube called the 6L6GE as an example. This was not an easy task, taking years. Using the original tooling was not all that hard (Aspen just bought it from a factory when it shut down), but setting it up properly was another costly story. Then the daunting tasks of those materials in the recipe was

the issue. Well, he pulled it off, after many years and many dollars. We now have a great NVM ( I coined that NVM by the way ... new vintage manufacture) output tube. It is not cheap, but it can be produced over and over now. I am not too worried personally on how long this tube can be produced, as I am 53, and I saw enough tonnage of original plate material metal to make enough of these to last at least my lifetime! Aspen is also planning the release of a GE 6CA7 in the summer of 2003, and this is on schedule at the point of this writing. There are a few other "surprises" in the near future.

There are other folks that work directly with some of the major tube factories. Some do this for a love of tone and amps, such as Aspen, while some do it for economics. The folks that do this for economic reasons seem to take shortcuts which show up in the end result product, as is the case in some of today's preamp tubes. Tom McNeil at Ruby Tubes is another tube supplier that financially backs new tooling for their own products at times. I have always found Ruby Tubes to offer great tubes which are nicely matched. Long before I came to GT, I had been a user of their tubes, actually since about 1982.

When it comes to new preamp tubes, keep in mind that today you have fair gain ... although all over the scale and inconsistent. You rarely have the other factors, output and TC. If you know your preamp tube vendor, your chances with new tubes are much better. GT, as an example, tosses about 50% of their tubes, as they have to meet tests for output, low noise, and a lack of microphonics. That is part of the reason for their cost that some folks feel is higher than some untested tubes.

The bottom line here, is that NOS tubes were superior to the products made today. If you cannot hear this and FEEL this, turn down your gain, raise your master, maybe learn what to listen for, and perhaps have your ears cleaned.

If after all that, you still feel there is not a difference, then you are fortunate to have standards which are easily met. BUT .... You still cannot escape the basic math and seeing that the data on today's tubes do not meet those of yesterday unless you have a vendor that will go through 1000 of them to find a few great ones. A proper spec tube will also have a much longer life, even if the tone is of no concern to you. When it comes to output tubes, having a matched set will also lower output transformer temperature, prolonging the life of your amp's other chassis internalized components.

## **Matching in more detail – static versus dynamic matching**

I have been using Groove Tubes products since about 1985. I have been working with amplifiers and musicians longer.

Over time I have heard comments in regard to the higher cost of Groove Tubes own tube offerings, and comments that they sell the same tubes as everybody else and just stick their name on them. In some cases, they do sell the **same** tubes, but the GT logo does not go on the tube until the tube goes through their own unique testing process.

On the subject of the **same tubes**, there are differences worth noting. Many tubes are made by the world's tube factories to specific GT designs and specifications. Some of these are the KT-66HP (which at first glance looks much like the Chinese variant, but is not made in China), the GT-E34LS which comes from the JJ factory but is not the same tube as the JJ E34L (look at the plate assembly), notice the heat sinks on the plates of the GT version), and other tubes such as GT's own, USA self made 6L6GE. The KT-88SV is a different tube in regard to plate assembly as another example. These are all tubes built off GT developed and produced tooling.

For tubes that you may think are the same, look at the bases. GT re-bases many of their power tubes with a different assembly. Look at some other company's blunt pins with dipped coatings. Feel the resistance when you plug those into your vintage Marshall or Fender as the female inserts in the tube sockets either feel like they are being deformed, or just as bad, the insert comes out of the socket? GT uses polished and tapered pins that are not pot metal. This is yet another change often overlooked. Vintage tube bases are a lot happier with these pins.

This is not the early 1960's anymore, and tubes are no longer widely used in medical equipment, scientific measurement equipment, or the Minuteman missile program. Quality control is not what it was four decades ago. In the past, a 12AX7 at 250 plate volts with a 2 volt bias would produce 1.2mA. Today, even the same maker, same batch, and run, will have tubes that vary from 0.6mA to about 1.8mA. Over 80% of these fall at below 0.9mA. This is one of the reasons that some of you have put **new** preamp tubes in your amp, only to have it sound worse than before. Maybe you had a 1.1mA tube in V1, and the new tube was 0.7mA. Groove Tubes has less than a 50% acceptance rate on their preamp tubes. They are tested for low output, microphonics, and noise. They carry a 180 day (6 month) warranty. I found other vendors in many cases had a high degree of low output, microphonics, and even one of the two sides of the triode not even working. Most of them replaced these tubes, but it took time and effort to send back the bad tube (after making a call or two, or sending letters), and then waiting for the "new" tube to arrive. It became quite obvious, that certain vendors did little more than put the tube in a box and ship it.

### **MATCHING and associated cost**

There are a lot of ways to **match** tubes. The most common and simple method is done using a fixed voltage, a fixed bias, and looking at the output of the tube. If it is within a certain range, the tube is labeled as "matched". This is very cost effective, taking a matter of a minute or so to check tubes. I call this the static method.

Over the years I noticed, that when I set bias on a performer's amp, after a week or so, I would have to reset the bias, as

things changed. I also noticed that when I used Groove Tubes, I did not have to re-bias the amps as had to be done on amps using non GT tubes. This was due to weak vacuum that was not discovered in tubes from vendors that did not test for vacuum, grid leakage, gas leakage, etc. If you suspect your vendor is saying they do test for this, and perhaps may use nothing more than a static current draw match, ask them what they use to match, and ask for this in writing if you ever plan to get them to replace tubes that died in the first few weeks. Even if a vendor has a long warranty, without testing for the above, they are banking on the odds that the tubes will hang in there, or you will hopefully not notice the difference, or it will be too much trouble for the customer to send the tubes back. (That is, if they even have a return policy for the reason of not liking the tubes).

I initially rarely thought all that much about all this, but over time, other things came to my attention. After a performance, the output transformers on GT equipped amps seemed to feel cooler than amps with statically matched tubes. I had less output transformer failures on client's amps that used GT tubes. I became more curious. It became apparent, that a mismatched output section had not only sonic issues, but perhaps also drove the output transformer harder. It was like using cheap oil in a good car versus good oil ... the engine lasted longer.

The static method was fast and simple, but it had some areas of concern for my clients.

The second method of matching uses what I call the dynamic method. Dynamic matching takes the static method a few steps further. It runs tests at various voltages and looks at factors that determine reliability of the tube, and what the character of the tube is over its entire operating range, like an amp works. Tubes that were statically matched within one milliamp, when thrown on curve tracers, were far from being matched in actual operation. Tubes that were dynamically matched, but from a static match were as much as 10% off match in a static idle match, when current, signal, and voltage sweeps hit the tubes, had their curves and match line up beautifully.

Think of it in this way.... A car that has not been tuned at all will idle roughly and sputter and stall. In a static matched application, the idle may be set to be very smooth, or perhaps if a different voltage and load is used, then the car runs fantastic at say, 4000 rpm. In a dynamic match, the car is run on the dyno, and you know how it will perform over its entire operating range. I can make my VW idle great, or run down the road at 60 mph nicely. Somebody else can do the same with a BMW M5. But, when we both step on the gas and hit that first corner, there will be a difference. Another more simple way of looking at this.... I can make my VW Jetta idle nicely at 800 rpm. I can make a friend's M5 also idle at 800 rpm. By some tube vendor's definition, these cars would be "matched". When my friend and I take off, hit the gas, the brakes, and the turns on Mullholland, what do you think will happen?

There were other factors too. GT also tests for gas leakage, grid leakage, low vacuum, as said earlier, as just a few points in their testing process... There is also a burn in period. This was where I learned even more. Today's cathode coatings are not as pure perhaps, as those in the past. There are impurities. Now, I am just guessing here, I have NO basis in scientific fact, but I feel that what is happening is that tubes that are not burned in before matching have gasification of the impurities in the cathode coating, and this changes the tube characteristics. Factors such as grid leakage also contribute to decreased reliability. That is why tube suppliers have guarantees... there are factors that are outside of some aspects of control. The guarantees were all well and good, but did not do a lot for my clients on stage when a tube failed. The GT tubes are tested for these aspects, and for me it has shown results.

If you think all of this is hype and does not matter, that is your opinion, and either you are open to additional information or not. There are

tubes like the new USA GT 6L6GE, that whether you think it is great or not, you may want to give it a listen before you jump on the word of some lone individual. Perhaps look to see what tube folks like **Eddie** use in his 5150s. Whether you like his music or not, its hard to miss that he has either a firm understanding of tone and a matched output section, or he is pretty darn lucky. He can get his harmonics and sounds anywhere on the fret board.

Tubes tested in a matter of a minute are going to cost less than tubes tested many times longer. Tubes that use premium components will cost more. Tubes made in the USA with USA parts and labor will cost more than Chinese or Russian tubes. Good oil costs more than cheaper oil in your car.

If you have learned something here or if this gives you course to seek more information, than that's great. If you think its all hype, and have not at least looked at some the unique GT designs, than I guess we will just go our different ways. It was nice meeting you informally here, as I am sure we won't be seeing each other in the future face to face, as we don't seem to run in the same sonic or tone circles. I am not saying that Groove Tubes are the only tubes that are any good. There are some terrific tube suppliers out there, and I support their products too. I support quality, whether its tubes, amps, guitars, or studio equipment.

If you want to contact me, I can be reached via the various forums in which I participate. You can also reach me via email from this website, or give me a call at Groove Tubes, where I have been spending time on a more formal basis since May 2002. When you go to their website at [www.groovetubes.com](http://www.groovetubes.com) be sure to take a look in their preamp tube section at the bottom for the **SAG** tubes. I did not have enough tubes at my own hands to find one in 20-50 that met my needs for graded and classified preamp tubes or matched phase inverters, so as of May I started working with GT and formed the SAG (Special Applications Group). I guess that means you may also call Groove Tubes most of the time if you want to speak on the phone one on one, or drop me an email there at [techsupport@groovetubes.com](mailto:techsupport@groovetubes.com) and if you are in the area and want to see how tubes are made in the USA (even though some folks say this is **hype** and GT does not make anything), drop me a line, maybe I can show you a few things, and have you listen to a few things.

## **Point to Point amps - some myths and also why some techs prefer them**

Point to Point (PTP) and Printed Circuit Board (PCB) amps - an ongoing debate that rages on.

Why do many of the most "non-technical" techs prefer these? I have my own theory and I am sure a lot of flak will be coming my way for my thinking on this. It is my personal thinking, whether you agree or not.

1. PTP is used, generally, on the most simple amp circuits. For a tech to find a problem, it is a much more simple matter of lifting one side of a component and metering it, than dealing with a circuit board mounted board.
2. The simple circuit design makes it easier to "shotgun" and find the bad component.
3. Many PCB amps bring in a lot of business. It is easy to justify high charges .... "man, this is a pretty darn old amp, it's bound to need a lot of work". Many of these amps make all sorts of "weird noises" too, as their components have no support other than the ends of the component leads. Think of them as big guitar strings with a weight in the middle.

Properly designed PTP amps are wonderful. Many are based on classic designs with simple tonefull circuits. On the best of them, they are costly, due to the attention to design and very high component costs. As an example, a 15 cent metal film resistor will be less costly than a 65 cent carbon comp resistor. When these amps are built and wired properly, with high grade parts, the result is magic.

Many amps are called PTP, but not true PTP amps. Fender amps such as most of the tweed era, are really more of a basic form of circuit board amp, a piece of tag board type of material is used to support the components. This was one factor that made the amps much more sturdy and road worthy than some of the other amps of the day. This construction was also used in the later Tolex amps.

There are amps that use other methods of "PTP" such as Hi Watt, Ashdown, and Roccaforte. These amps use turret boards or standoffs. Here, the components are physically supported with shorter leads, and one component does not drag another and another to it's next attachment point. These amps are some of the highest caliber and strength in construction. This was the sort of construction used in military gear in the past.

PTP wired amps, true PTP, can be very inconsistent without a very high degree of attention to detail and testing. With a modern PCB amp, there are circuit simulators, that do the board layout with the trace runs optimized for the least noise and best performance. In a true PTP, two amps can sound very different. Also keep in mind, that in the past, true PTP amps were built with some of the least expensive labor they could find, which often reflected in the end product. Checking these old PTP amps though, was easier, as they were of very simple design.

There are some great PTP amps, such as Steve Carr's amps, but you won't find these cheaply. High grade components and components anchored and wire strain relieved, is all part of the cost of these amps. On the "hybrid" PTP amps, such as the Fender Tweed style newly made amps, you have folks like Victoria. Again, attention to the highest grades of construction and parts help here. On the turret board front, you have folks like Roccaforte. None of these amps are cheap, and each of them are worth every penny of their retail cost.



PCB amps .... why some techs don't like them. Again, complex design more often due to multi channels, switching effects loops, and other features. It is hard for the "technically challenged" to find a problem. They are less expensive at the lower or entry end of the amp scale, and offer a lot of features for the dollar, but at times use lower cost components and faster construction methods. There are hybrid folks, that use the best of PCB and PTP such as Andy Marshall (THD) as just one example. Chassis mounted tube sockets wired to a PCB substrate that is many times thicker than most F-16 PCBs, and traces on the PCB that are so thick, that a moto tool is needed if you ever want to cut one of them.

A well built amp, well designed, and using great components, is a great amp, whether PTP, Hybrid, or PCB.

My most "supported" amps, those in the shop the most often, are the true PTP amps that are out on tour on the road, that were done by "boutique" designers that jumped on the vintage bandwagon. They have parts that are true PTP, not tagboard (as the Fender Tweed and Tolex era amps), and not turret board, but true PTP. These amps have those bigger caps, just hanging out in space, swaying around as the equipment truck or bus bounces hundreds of miles down the road, from city to the next city. These amps end up with cracked solder joints at best in many many cases, and most of them play their own symphony physically, depending on the note coming out of the speaker, as the components resonate.

So, before you consider an amp with PTP vs. PCB vs. Hybrid, do a little more thinking. If it is a multi channel amp with switching ability, the last thing I'd personally ever buy would be a NON-PCB amp in this arena.

If your tech thinks that replacing a component on a PCB board is hard, then frankly, find a new tech. Components have been replaced for decades on computer and military PCB's where folks lives rely on the unit .... not just a simple guitar amp. BUT, there is a bit of proper soldering knowledge attention, and the proper tools, which are pretty darn easy to come by. If you tech complains about burnt etches and problems in PCB's, this may be from first hand experience, and you may want to consider a different tech in the future. If they can't do this right, they are probably making other mistakes much bigger in other areas.

Just as a close, some of what I think are the finest examples of various types of amp construction today in some examples:

Pure PTP - Steve Carr Amplifiers

Turret Board Mil Spec – Roccaforte / Dr. Z / Mako

PTP/PCB - Groove Tubes Soul-O series amps, and THD Electronics - The best of both worlds.

PCB channel switching high grade - Rivera Amplifiers / Peter Diezel

PTP Tagboard (Fender tweed/tolex era) - Victoria Amplifier / Clark Amplifier

PCB general - Fender amplifier in the reissue series amps and Pro Tube series.

I know there are many others, but to me, these are the best of the best. In the case of each of the above, there are some points where they excel in all areas. Rivera amps (look at the cabinet construction ... no self tapping wood screws as an example, but machine screws). Victoria amps (look at the components, the wiring, and overall detail). THD (look at the boards, the traces, and overall detail). Carr (components, properly supported runs and parts, and overall detail). Roccaforte (overall detail, parts, and the amps are literally bomb proof). Fender new amps (very nice PCB work in the target price range. Give me a "reissue" twin, super, or deluxe, and a few hours, and then you tell me which the original is after playing).

I know this will "piss off" a lot of folks, especially some amp techs, and folks that may have spent way too much for amps that jumped on the vintage bandwagon perhaps. There are many great amps that I did not mention, as this was long enough already, and the amps above I mentioned, have had no downtime due to failures over the time I have worked on them for general upkeep.

I am now ready for folks to pick one or two details of the above, and write scathing retorts, rather than seeing the overall picture here. Reissue versus the original amps - part II of Point to Point amps - some myths and why some "poor" techs love them .... continued.

In the above writing, there may be the misconception that I was saying that the reissue amps can "be" every bit the same as the originals. This is not the case in many ways. It had also been pointed out that true PTP does not have minute intercapacitance issues that would be the same as a tag board amp as an example. These are all issues that can be debated forever.

On this second point, the tag board issue, one needs to remember, that guitar amps are a different breed than audio amps. Audio amps attempt in design, to be "flat" and not color the sound over the intended frequency range. In guitar amps, they have coloration. This is why we love them, and prefer one over another. The construction and components are a part of this sonic area.

When comparing an original amp like a Fender Super Reverb with it's original, it is easy to make an observation if we compare to cars as one example. The original and reissue of the amps can be made to sound very much the same when recording. This is different than actual playing. Like a car, if a BMW M5 is shown in a movie, it is still a car we recognize, whether filmed in 35mm, or on video tape. Same car, same color, and same driving direction. If we sit in the back seat of the actual car, it is also different than the experience of actually driving the car. It is much the same with guitar amps and playing.

If one plugs something like a POD, and we plug into a mixer with a CD of a know artist where we can play along, we can dial up the "same" amp as was used, play the same riff, and it sounds the same or at least very close to another typical listener (maybe not a player themselves). The reissue amp can be made to sound close, or even "better" than a lot of the original amps. Part of this is because the original amps in many cases, have not been maintained.

If we take an original, and set it up properly, now we can do a more accurate test. The amps will generally have the same general sound, but the player reaction and touch dynamics will be different. There are many reasons for this. Some of these reasons are things like transformers in the originals (their material, interleaving, voltages), capacitors, and resistors. In the case of even a simple item like a resistor, the original amps used carbon composition resistors rather than the metal film resistors of today. The carbon comps are not as stable, and as they get warmer, their value changes. This makes them more musical to many folks tastes. The top makers of some amps like the Fender Tweed style of people like Mark Baier of Victoria, only use items such as CC resistors, the proper caps, transformers, and

construction methods and materials. Most reproductions or reissues from the original maker though, use metal film resistors, different caps, and in many cases, circuit boards. The amps may sound similar, but will "drive" very differently.

Part of the joy in music that is not in the realm of the "non-player", is the vast dimension of the playing of the instrument and the interaction of the instrument (guitar-amp) with the player in touch dynamics and countless additional areas. If you want to just lay down a track that sounds like the original, then many amps or virtual amps are available. In a live application, the differences become more of a factor, and if a player, an even stronger set of issues. You don't have to be some "monster" player either. In fact, at times, the "better" or more articulate the amp, the better one may sound. Hit an "A" note on one of the upper strings while sitting right next to an amp. It should be at a lower level. Try to observe, where the note or sound is sitting on the face of the speaker cone in your mind. As the note decays, does it sit in the same spot, or "swirl" around the speaker cone to various areas around and more and less toward center? If it moves, you have an articulate amp, or perhaps a good speaker, a matched output section and great tubes perhaps. This is just a part of the difference that you will see happen more often in the original amps or the amps from some of the great makers.

## Recording your guitar

An additional book could be written on this subject, but I will try to hit a few points briefly.

Many folks record using the Shure SM57 microphone. Why? Maybe it is one that is everywhere, does not need phantom power so it is found on stages of many performers or just because "its what everyone uses". Everyone uses? Not for those in the "know". The best sounds that capture the sonic nuances of an articulate or even distorted guitar like, in fact LOVE, GREAT MICS. Large diaphragm condenser mics are generally preferred, or very accurate condenser mics such as the GT-44 are the ticket. A great guitar, amp, and performance are missing an essential aspect if using a cheap dynamic mic.

Microphones do NOT LIKE high levels. Overload the board, where one has to use input pads and turn down the gain to keep the meters out of the "red", and now your board does not have the optimum S/N ratio to boot. This is why lower wattage amps cranked wide open are the ticket ... the record much LARGER than a giant amp padded.



Mic preamps are critical. The cheap \$199.00 tube mic preamps are fine for generic work, but properly terminating a microphone will make all the difference in the world, even with a cheap dynamic microphone. For those of you that have heard the ViPRE demos at NAMM, you know what I am talking about. If you want to know about the ViPRE, and have access to the folks using them, the studios using them, the reviews, tech info, owner's manuals, etc., just head to [http://www.groovetubes.com/product.cfm?Product\\_ID=1602](http://www.groovetubes.com/product.cfm?Product_ID=1602) and download all the attachments on this page and read them SLOWLY and carefully.

The GT microphones are distributed in the USA by M-audio (<http://www.m-audio.com/products/gtmics/microphones.php> ) for the most part. The GT55 I believe is also handled by Guitar Center and possibly additional high end audio folks. The area on the Groove Tubes website that has mic info is at [http://www.groovetubes.com/microphones.cfm?ObjectGroup\\_ID=124](http://www.groovetubes.com/microphones.cfm?ObjectGroup_ID=124) and other GT studio gear from the GT custom shop is located at [http://www.groovetubes.com/studio\\_electronics.cfm?ObjectGroup\\_ID=125](http://www.groovetubes.com/studio_electronics.cfm?ObjectGroup_ID=125)

## **Guitar Speakers**

This document is primarily a tube document, but as you may have seen, other side aspects related to tubes have been covered.

I am including a few links here for speakers, where the most common bigger name folks will be listed. In this way you can head directly off to their websites by clicking the links here in this document. On the manufacturers websites are all the speaker specifications and response curves and graphs.

Jensen can be found at [www.jensenvintage.com](http://www.jensenvintage.com)

Eminence can be found at [www.eminence-speaker.com](http://www.eminence-speaker.com)

Celestion can be found at <http://professional.celestion.com>

## Tube Test Results December 2003 and Beyond

### Groove Tubes NVM Mullard 12AX7 Series 1 – Original Spec

DATE	TUBE	B+ volts	BIAS volts	mA actual	TC (gm) actual	gp	Gain	Comments
Expected				1.2	1600		100	
12/16/2003	12AX7M I 1	250	-2	1.1	1530	0.018	85.00	Very close to current 12AX7C in spec Very consistent Traces like the II - maybe just a different plate color? Traces like your Mullards which are on file and in your room. A great "on-spec" Mullard 12AX7 with the original plate color. Better than the black plate spec wise
	12AX7M I 1			1.1	1500	0.018	83.33	
	#2			1.3	1600	0.02	80.00	
	#2			1.1	1490	0.018	82.78	
	#3			1.2	1580	0.019	83.16	
	#3			1.2	1610	0.019	84.74	
	#4			1.2	1610	0.019	84.74	
	#4			1.2	1630	0.019	85.79	
	#5			1.1	1480	0.018	82.22	
	#5			1.2	1580	0.019	83.16	
	<b>Averages</b>			<b>Output</b> 1.2	<b>TC</b> 1561		<b>Gain</b> 83.49	<- Output averages
				97.5%	97.6%		83.5%	<- % of standard spec
	<b>High TC</b>			1610	100.63%			
	<b>Low TC</b>			1490	93.13%			
	<b>QA tolerance TC</b>			7.5%				
	<b>High mA %</b>			1.3	108.3%			
	<b>Low mA %</b>			1.1	91.67%			
	<b>QA tolerance mA</b>			16.7%				
	<b>High gain</b>			85.79	85.79%			
	<b>Low gain</b>			80.00	80.00%			
	<b>QA tolerance gain</b>			5.8%				

## Groove Tubes NVM Mullard 12AX7 Series 3 – “Super Mullard”

DATE	TUBE	B+ volts	BIAS volts	mA actual	TC (gm) actual	gp	Gain	Comments
<b>Expected</b>				<b>1.2</b>	<b>1600</b>		<b>100</b>	
12/16/2003	12AX7M III 1	250	-2	2.0	2080	0.023	90.43	Perfect A/B match and trace
	12AX7M III 1			2.0	2080	0.023	90.43	Some even flash like a Mullard when
	#2			1.8	1940	0.022	88.18	first turned on
	#2			1.8	1930	0.022	87.73	Matched triodes in many - high %
	#3			2.0	2130	0.025	85.20	These are all very quiet and
	#3			2.2	2150	0.025	86.00	non-microphonic physically
	#4			2.8	2330	0.027	86.30	On a old tube tester, these would
	#4			2.5	2300	0.024	95.83	test amazing
	#5			1.8	2050	0.024	85.42	THE tube for PCB complex channel
	#5			2.1	2190	0.025	87.60	switching amps.
	<b>Averages</b>			<b>Output</b> <b>2.1</b> <b>175.0%</b>	<b>TC</b> <b>2118</b> <b>132.4%</b>		<b>Gain</b> <b>88.31</b> <b>88.3%</b>	<- Output averages <- % of standard spec
	<b>High TC</b>			<b>2330</b>	<b>145.63%</b>			
	<b>Low TC</b>			<b>1930</b>	<b>120.63%</b>			
	<b>QA tolerance TC</b>			<b>25.0%</b>				
	<b>High mA %</b>			<b>2.2</b>	<b>183.3%</b>			
	<b>Low mA %</b>			<b>1.8</b>	<b>150.00%</b>			
	<b>QA tolerance mA</b>			<b>33.3%</b>				
	<b>High gain</b>			<b>95.83</b>	<b>95.83%</b>			
	<b>Low gain</b>			<b>85.20</b>	<b>85.20%</b>			
	<b>QA tolerance gain</b>			<b>10.6%</b>				

## 12AX7WC Sovtek – 0310 datecode

DATE	TUBE	B+ volts	BIAS volts	mA actual	TC (gm) actual	gp	Gain	Comments	
Expected				1.2	1600		100		
12/17/2003	Sovtek 12AX7WC	250	-2	1.2	1310	0.015	87.33	New production Sovtek 12AX7 tube 0310 datecode batch Gain pretty good, better than average of today's 12AX7s. <u>Rise time a touch on the low side in traces.</u> Quiet and free from physical microphonics. Much more microphonic free than LPS, Ei 7025, or JJ ECC83. A stong improvement over the past WA, WB and WXT+ tubes. Good current output - better than JJ ECC83	
				1.4	1450	0.016	90.63		
				1.3	1410	0.016	88.13		
				1.3	1460	0.016	91.25		
				1.6	1470	0.017	86.47		
				1.2	1390	0.015	92.67		
				1.0	1260	0.014	90.00		
				1.0	1280	0.014	91.43		
				1.5	1590	0.0175	90.86		
				1.4	1570	0.017	92.35		
	<b>Averages</b>			<b>Output</b> 1.3 107.5%	<b>TC</b> 1419 88.7%		<b>Gain</b> 90.11 90.1%		<- Output averages <- % of standard spec
	<b>High TC</b>			<b>1590</b>	<b>99.38%</b>			Additional Comments: Good current output missed in most of today's new 12AX7s. These would be great in complex circuit front ends such as Fender Hot Rod series, Bogner, Mesa, or channel switching amps. Good tube for effects loops and reverb drivers. Current spread QA a bit wider than I like but this was rare. Maybe 1 tube in 10 Overall, great current output and great gain too. Best production output / gain as of 12/17/03 other than 12AX7M	
	<b>Low TC</b>			<b>1260</b>	<b>78.75%</b>				
	<b>QA tolerance TC</b>			<b>20.6%</b>					
	<b>High mA %</b>			<b>1.6</b>	<b>133.3%</b>				
	<b>Low mA %</b>			<b>1.0</b>	<b>83.33%</b>				
	<b>QA tolerance mA</b>			<b>50.0%</b>					
	<b>High gain</b>			<b>92.67</b>	<b>92.67%</b>				
	<b>Low gain</b>			<b>86.47</b>	<b>86.47%</b>				
	<b>QA tolerance gain</b>			<b>6.2%</b>					



**12AX7WC Sovtek – 0311 datecode – production test of Sovtek bulk delivery**

DATE Expected	TUBE	B+ volts	BIAS volts	mA actual	TC (gm) actual	gp	Gain	Comments
				1.2	1600		100	
1/20/2004	Sovtek 12AX7WC 0311 datecode	250	-2	0.9	1100	0.013	84.62	Original test batch from New Sensor showed great results. Factory shipments showed different results. It may be that the initial samples were cherry picked. - This batch is from Sovtek current production. VERY inconsistent - noisy / 3db on average more noise than WA/WB
				1.2	1350	0.015	90.00	
				1.4	1510	0.017	88.82	
				1.7	1710	0.019	90.00	
				0.9	1200	0.013	92.31	
				1.0	1260	0.014	90.00	
				0.8	1140	0.013	87.69	
				0.8	1080	0.012	90.00	
				0.8	1120	0.013	86.15	
				1.0	1230	0.014	87.86	
	<b>Averages</b>			<b>Output</b>	<b>TC</b>		<b>Gain</b>	
				1.1	1270		88.74	<- Output averages
				87.5%	79.4%		88.7%	<- % of standard spec
	<b>High TC</b>			1710	106.88%			ADDL Comments:
	<b>Low TC</b>			1080	67.50%			Matching not good.
	<b>QA tolerance TC</b>			39.4%				Good gain but low TC and high noise.
	<b>High mA %</b>			1.7	141.7%			
	<b>Low mA %</b>			0.8	66.67%			
	<b>QA tolerance mA</b>			75.0%				
	<b>High gain</b>			92.31	92.31%			
	<b>Low gain</b>			84.62	84.62%			
	<b>QA tolerance gain</b>			7.7%				

## Some posts from music forums

These forums such as those at [www.harmonycentral.com](http://www.harmonycentral.com) and [www.musicplayer.com](http://www.musicplayer.com) where I participate, may give a bit more information on some subjects. On the Music Player Guitar Forum, (Guitar Player Magazine), there is also a post called "Feel free to ask Myles" where I answer technical questions for folks. I am also the moderator of this particular forum

This was from a post on Harmony Central which as titled: **Does anyone on here even LIKE GT tubes?**

---

*Originally posted by Mr.Strat*  
**Hey miles do you work for GT**

---

Mr.Strat .....

Yes..... I work for GT part time. I came to GT about a year ago.

I also have my own company, Guitar Amplifier Blueprinting, and we have used GT tubes since the mid or early 1980's, and I was writing about them long before I came to GT.

I also do tube testing and production verification on all of the tubes from all of the current factories (as one aspect of Guitar Amplifier Blueprinting), and verify the matching of many of the Internet tube vendors and document the results.

I also have written reports and done tests on Magic Parts (Ruby Tubes) and if you look in their 2003 catalogue, some of my reviews are in there, which were taken from some of my test results. Ruby did not pay for the tests or supply the tubes, the tubes are purchased at retail.

Most of my test results are published on my website, for earlier tests (before I came to GT in many cases), and the current and ongoing testing is now updated in my tube primer document mentioned on my website.

---

*Originally posted by Mr.Strat*

**I just wanted to know cause if I email GT support. Would they be able to tell me how certain tubes sound?**

---

Mr.Strat .....

If you email GT support, you will be emailing me. I am GT Tech Support, I am also the head of GT SAG (special applications group .... sort of the custom shop for tubes).

The SAG is sort of how I came to GT actually. I used to come to GT and pick through tubes for my clients using high end test gear looking for specific characteristics. I guess I bugged them so often that at one point Aspen said "you are around here so much, we may as well give you a desk". I created the SAG when I came to GT.

---

*Originally posted by Ole Man Blues*

**Myles:**

**Thank you for stepping in and sorting out the FACTS from the "so called facts".**

**When I think back at the Groove Tubes I've used I've never had one fail on me. The tonal quality has always been Top Shelf. Paying a few extra dollars for a reliable product makes "cents" to me. People throw off on them because the tubes they sell are not made exclusively by GT.**

**I have used other name brands and fell into the hype, but GT has always given me a rock steady performance. What else can you ask for, especially in a fragile electron tube.**

**Ole Man Blues**

---

Ole Man Blues .....

Thanks for the feedback.

I sort of ended up at GT the same way ... after two decades of using their stuff, I noticed they stayed in balance / match, lasted longer, so just kept using them.

Like I mentioned earlier in this post somewhere, there are a few folks that support the tube companies financially, such as GT, Sovtek, Ruby. These are folks that pay for the tooling in many cases for their own tubes.

Sovtek, Electro Harmonix (Both New Sensor - Mike Mathews owned companies .... and he also owns a chunk of Svetlana too), GT, and Ruby, all have some of their own designs. The Reflektor Plant in Moscow, is for the most part, New Sensor owned or supported. In the case of Tesla (now JJ), once also Teslovak, this was owned or supported by Groove Tubes in the past. This is where the E34Ls was developed.

The E34Ls, KT88SV, KT66HP are all Groove Tubes products, not sold by others under any other name.

The 6L6GE and soon to come 6CA7 GE USA tubes, are GT produced tubes which are only sold by GT or through GT dealers.

Mike Mathews of New Sensor (Electro Harmonix and Sovtek) is somebody that I also have to tip my hat to. He is putting tons of money into Reflektor and Svetlana, and without his financial help, these places might just vaporize into thin air. Not only has Mike Mathews brought life into these facilities, but more than just keeping them afloat, he has developed new tooling and new tubes (and also effects and all sorts of cool stuff). The new offerings from Electro Harmonix, such as the 12AX7EH and the 6V6EH, are some of the best tubes of their type around ... new or NOS. The new rectifier from EH is amazing and a great unit, and leave it to EH to come out with NEW octal preamp tubes. Well done Electro Harmonix is all I can say.

Tom McNeil (Magic Parts / Ruby Tubes), does some of the same sort of thing in China. The Ruby EL34BSTR is one of the finest EL-34 tubes I have ever tested.

So, from my point of view, a big thanks to Tom, Mike, and Aspen for not only keeping the tube industry alive, but making it grow and the quality improve.

---

*Originally posted by Luqman Aziz*

**Cool. What is the ratio of tubes that are rejected and the ones that are accepted when GT test their tubes? I heard the difference is a lot as GT only takes the best ones.**

**Luqman**

---

Luqman

The ratios vary every batch. There are basically a number of tests that are run.

On preamp tubes - gain, output, noise, microphonics are all tested. There are two sets of scales taking these factors into consideration. The tighter scale is what is used for the GT tubes that most folks see. The ones that do not fit the tight scale, are sold for less as the GT Silver Series line. The ones that do not pass the Silver Series standards are scrapped.

The microphonic tests are time consuming, as there are some tubes that are not initially microphonic, but after a dozen or so amp cycles of on and off, where the glass and mica heats and cools, the tubes can become microphonic. That is why, after passing the tests, the GT preamp tubes have a six month guarantee against becoming low in output, noisy, or microphonic.

When it comes to reject rates, as I said, it varies. The Chinese (latest Shuguang ... NOT SINO) generation 9 tooling, have a reject rate of

about 15%. The Electro Harmonix 12AX7EH has about the same reject rate.

The JJ ECC83 has about a 50% reject rate.

The Ei tubes average 60% rejects, but two factory shipments ago, this was 90%, that is, only 1 in 10 tubes were good and passed. The rest were trashed, so you can get an idea of the economics here.

The 12AX7LPS Sovtek was at about 35% rejects, and the 12AX7WA Sovtek varied about 45%.

On top of the out and out rejects, these tube all vary within the same batch as far as specs. This data is in my reports, which is sent to the various folks that hopefully will do something about it. In the case of the Chinese, they make changes very fast.

On power tubes, it is much more complex. They are tested for gas leakage, grid leakage, low vacuum, noise, and microphonics. New production with a higher percentage of impurities in the cathode coatings and plate materials, when heated, emit or give off various gasses. This shortens tube life, and also caused the tubes to come out of match much faster than tubes of the past in most cases. Record the bias when a tube set is newly installed, and check it 50 hours later. You will see it may have drifted a lot. Do the same thing with NOS tubes. You will see much less change.

On the USA GT 6L6GE, these are very pure materials and very high vacuum. Before I came to GT, I was testing these for them before they were release. I started testing in February of 2002. The tubes run class A at 105% spec, with a signal, 24 hours a day seven days a week. In the first 6000 hours, they changed less than 5%. The tubes are still running, at this point with about 11,600 hours on them. Most 6L6 tubes such as a Svetlana 6L6 will fail at about 4500 hours, and most EL34 tubes at less than 3000 hours.

The reject rates on output tubes is even higher than preamp tubes at times. This is because there are additional factors that need to be addressed with requirements to be met.

.....

Myles Saunders Rose has worked in various development, design, support roles, projects including development work for Roland, Yamaha, and was Apple Computer's music consultant for the Vivarium project in the late 1980's. He currently has his own company, Guitar Amplifier Blueprinting, and also is the head of the SAG (Special Applications Group) at Groove Tubes and Tech Support at Groove Tubes. He started playing guitar at the age of 8, on equipment that is called vintage today.... when it was NEW. He will not generally admit that he played the accordion from the age of five ... but then again, there were only five or so channels on the television, and one was dominated my Lawrence Welk back in those days!

Myles S. Rose - Guitar Amplifier Blueprinting - 2003

<http://www.guitaramplifierblueprinting.com>