

# TC9176P, TC9177P

T-77-21

Unit in mm

## HIGH EFFICIENCY ELECTRONIC VOLUME

The TC9176/77P is an electronic volume IC that has been developed for use on acoustic equipment. This IC is capable of controlling volume, balance, and loudness by externally inputting serial data.

- Volume control at 40 steps ranging from 0dB to -76dB at 2dB per-step and  $-\infty$ .
- Owing to the built-in 2 channels of L and R, which can be controlled independently, balancing is possible.
- Provided with the built-in loudness ON/OFF control function (TC9177P only).
- Being in the high voltage C-MOS structure, a wide dynamic range and low distortion are realized.
- Operation by two power supplies (+, -) is possible, and serial data input operates at logic level (0~5V), so the interfase with a micro computer is easily available.
- Package

TC9176P (without Loudness) 16 pins

TC9177P (with Loudness) 20 pins

## PIN CONNECTIONS

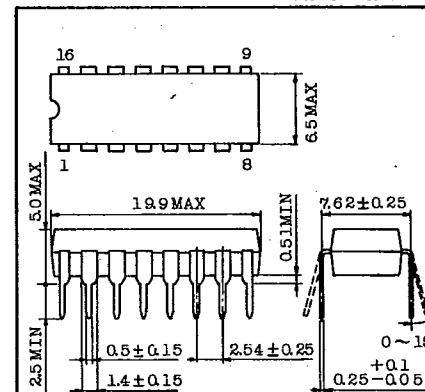
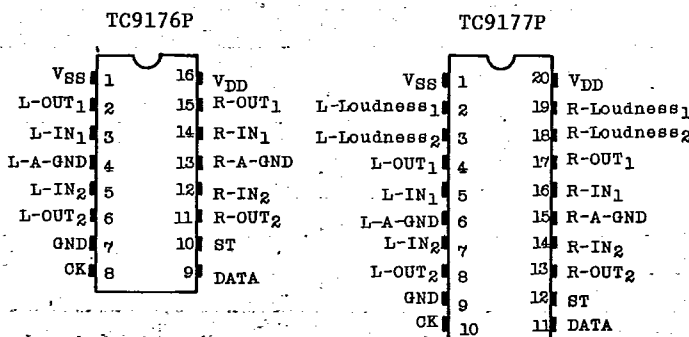

Lead pitch is 2.54 and tolerance is ±0.25 against theoretical center of each lead that is obtained on the basis of No.1 and No.16 leads.

JEDEC

TOSHIBA 3D16A-P

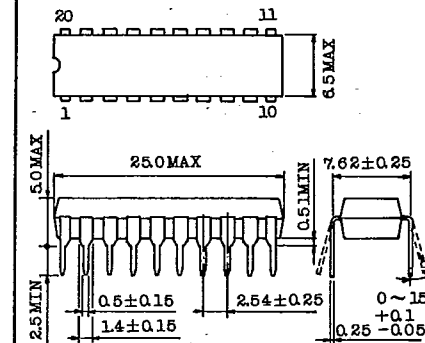

Lead pitch is 2.54 and tolerance is ±0.25 against theoretical center of each lead that is obtained on the basis of No.1 and No.20 leads.

JEDEC

TOSHIBA 3D20A-P

AUDIO DIGITAL IC

# TC9176P, TC9177P

T-77-21

## MAXIMUM RATINGS

CHARACTERISTIC	SYMBOL	RATING	UNIT
Supply Voltage	V <sub>DD</sub>	V <sub>SS</sub> -0.3 ~ V <sub>SS</sub> +36	V
Input Voltage	V <sub>IN</sub>	V <sub>SS</sub> -0.3 ~ V <sub>DD</sub> +0.3	V
Power Dissipation	P <sub>C</sub>	300	mW
Operating Temperature	T <sub>opr</sub>	-30 ~ 75	°C
Storage Temperature	T <sub>stg</sub>	-55 ~ 125	°C

ELECTRICAL CHARACTERISTICS (Unless otherwise specified, V<sub>DD</sub>=15V, V<sub>SS</sub>=-15V, T<sub>a</sub>=25°C)

CHARACTERISTIC	SYMBOL	TEST CIR-CUIT	TEST CONDITION	MIN.	TYP.	MAX.	UNIT	
Operating Supply Voltage Range	V <sub>DD</sub> -V <sub>SS</sub>	-	(Note 1)	7.5	~	32	V	
Operating Supply Current	I <sub>DD</sub>	-		-	0.5	3.0	mA	
Input Voltage	"H" Level	V <sub>IH</sub>	DATA, CK, ST Terminals	4.0	~	V <sub>DD</sub> +0.3	V	
	"L" Level	V <sub>IL</sub>		-0.3	~	1.0	V	
Total Resistance	ATT1	R <sub>ATT1</sub>	-	80	120	160	kΩ	
	ATT2	R <sub>ATT2</sub>	-	10.0	14	20	kΩ	
Step Error	ATT1	STEP(1)	f <sub>in</sub> =DC~20kHz R <sub>L</sub> =∞	0~-30dB	9.2	10	10.8	dB
	ATT2	STEP(2)		-40~-70dB	8.8		11.8	
Total Harmonic Distortion Factor	ATT1	THD(1)	*1	f <sub>in</sub> =20 ~ 20kHz	-	0.003	0.005	%
	ATT2	THD(2)	*1	V <sub>in</sub> =1.0V <sub>rms</sub> 0dB	-	0.003	0.005	%
Max. Attenuation	ATT(max)	-		90	-	-	dB	
Output Noise Voltage	V <sub>N</sub>	*2	0dB Position f <sub>out</sub> =20 ~ 20kHz, R <sub>g</sub> =1kΩ	-	2	10	μV <sub>rms</sub>	
Channel Separation	C.S	*2	V <sub>in</sub> =1V <sub>rms</sub> , f <sub>in</sub> =1kHz	80	-	-	dB	
Max. Operating Frequency	f(max)	-		-	-	500	kHz	
Min. Clock Width	"H" Level	T <sub>CK(H)</sub>	-	-	1.0	-	μs	
	"L" Level	T <sub>CK(L)</sub>	-	-	1.0	-	μs	
DC Offset Voltage	V <sub>DC</sub>	-	0dB	-	-	2	mV	

Note 1 : The operating voltage is decided by the voltage between V<sub>DD</sub> and GND, so in case of two power supplies it is ±7.5~±16V, and in case of one power supply, 7.5~16V.

TOSHIBA

# TC9176P, TC9177P

BLOCK DIAGRAM

T-77-21

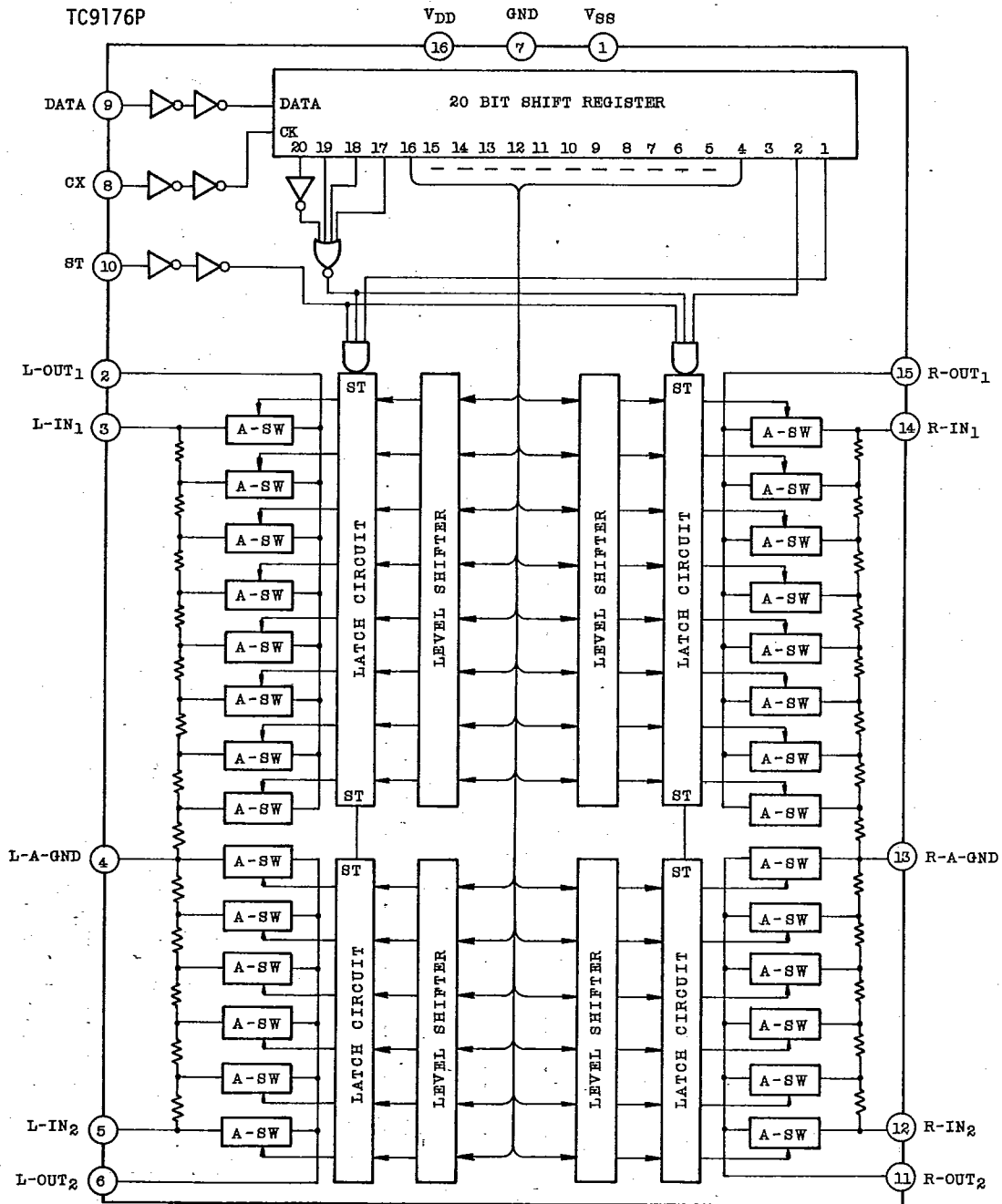

AUDIO DIGITAL IC

# TC9176P, TC9177P

T-77-21

## BLOCK DIAGRAM

TC9177P

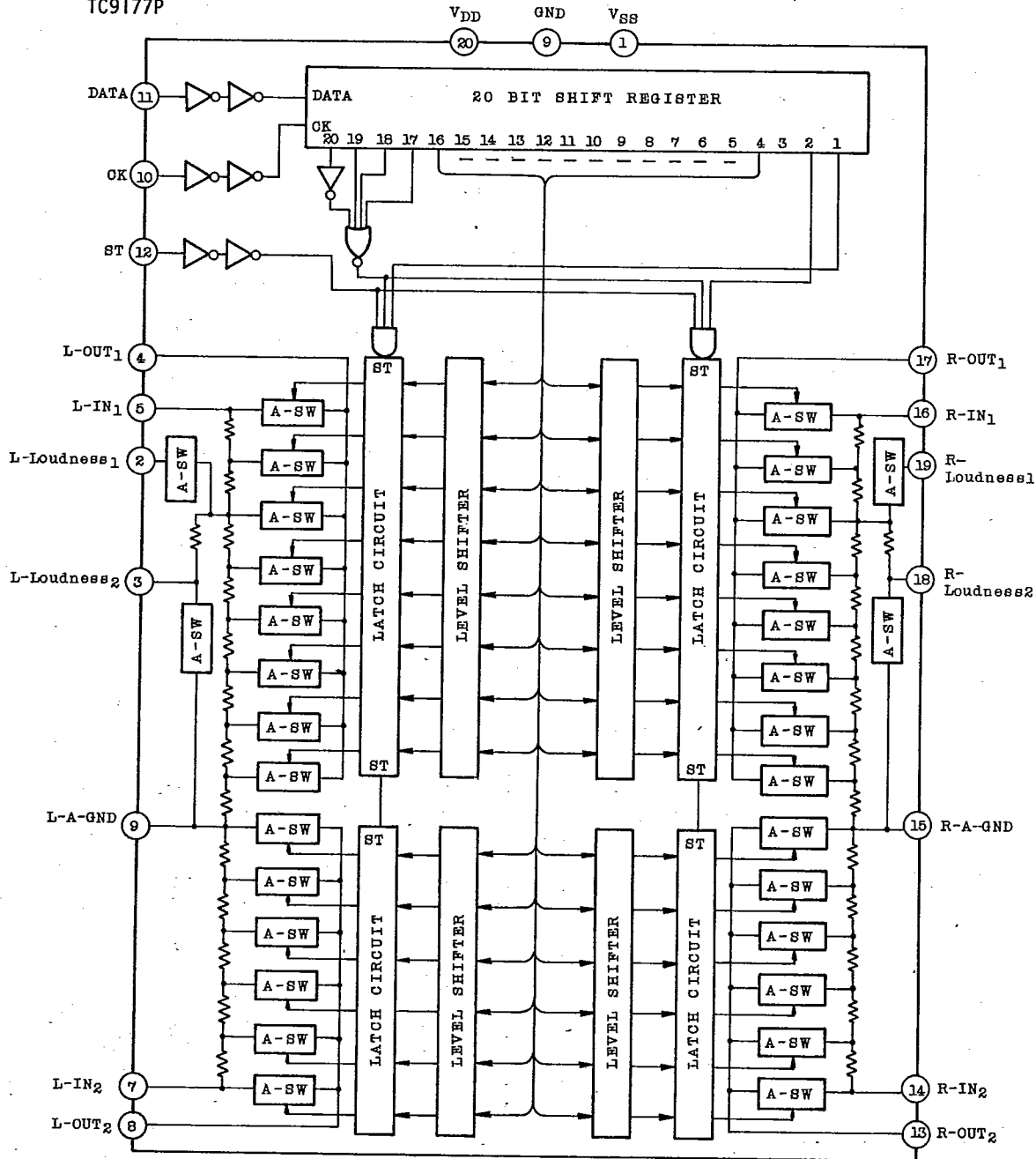

**TOSHIBA**

# TC9176P, TC9177P

T-77-21

## MEASURING CIRCUIT

### 1. TOTAL HARMONIC DISTORTION FACTOR

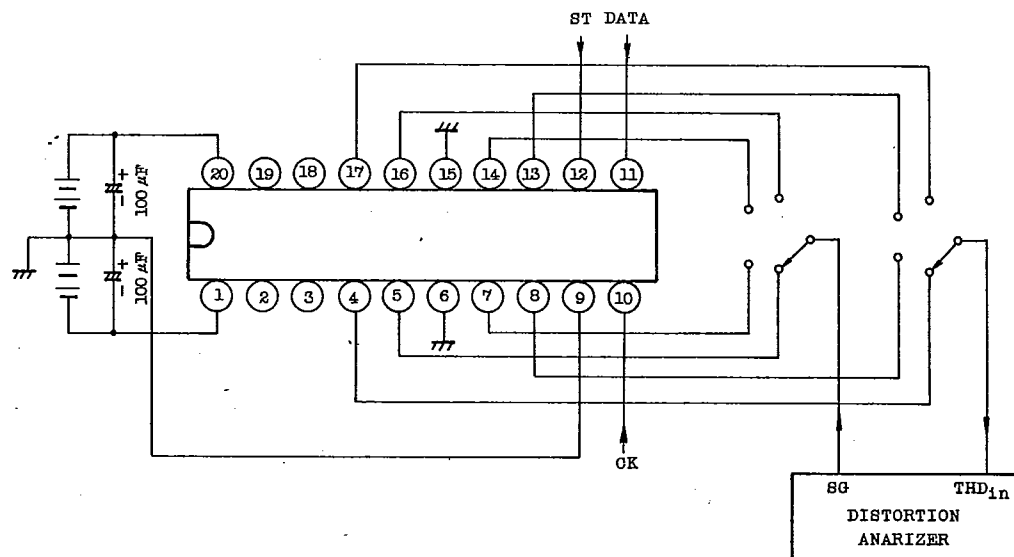

### 2. OUTPUT NOISE VOLTAGE

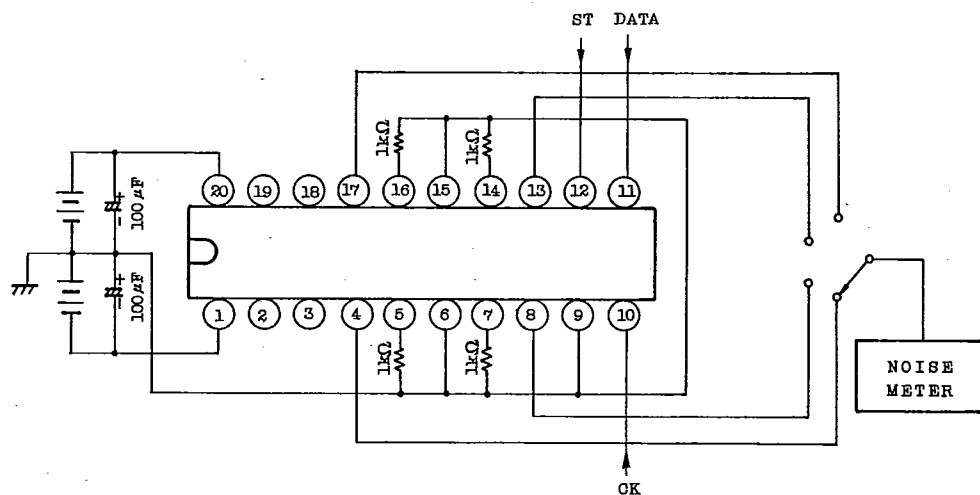

AUDIO DIGITAL IC

# TC9176P, TC9177P

T-77-21

### 3. CHANNEL SEPARATION

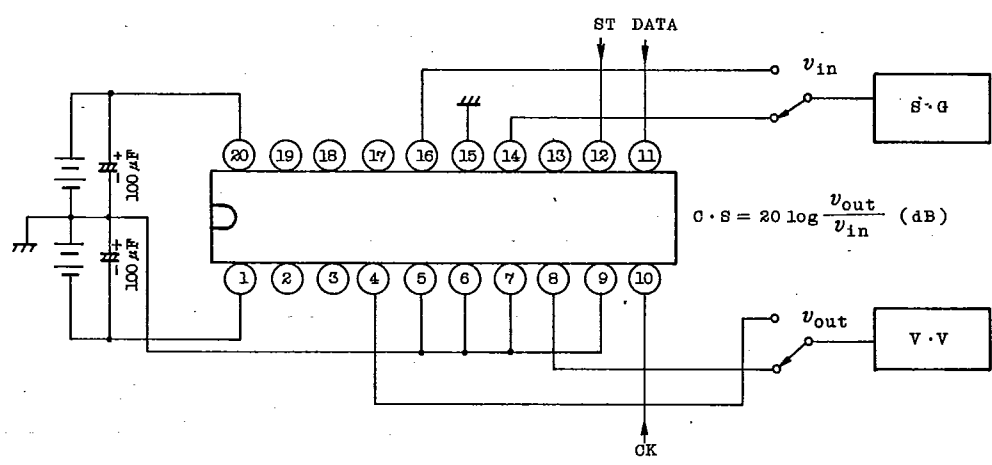

**TOSHIBA**

# TC9176P, TC9177P



9097247 TOSHIBA. ELECTRONIC

02E 18240 D

T-77-21

## FUNCTIONAL DESCRIPTION OF EACH TERMINAL

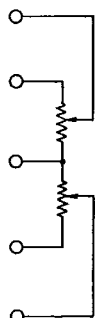
TC9176P

TERMINAL No.	SYMBOL	FUNCTION	REMARKS
2 15	L-OUT <sub>1</sub> R-OUT <sub>1</sub>	10dB/Step attenuator output. Signal applied to IN is attenuated in 8 steps from 0dB to 70dB at 10dB/step.	(L/R) 
3 14	L-IN <sub>1</sub> R-IN <sub>1</sub>	10dB attenuator input.	5/14
4 13	A-GND	Analog ground terminal.	4/13
5 12	L-IN <sub>2</sub> L-IN <sub>2</sub>	2dB attenuator input.	5/12
6 11	L-OUT <sub>2</sub> R-OUT <sub>2</sub>	2dB attenuator output. Signal applied to IN is attenuated in 5 steps from 0dB to 8dB at 2dB/step.	6/11
9	DATA	Attenuation level and channel selection data input. This data inverter consists of 20 bits and is input by CK signal.	Low threshold inverter 
8	CK	Clock input terminal. Clock input terminal for taking data from the DATA terminal.	Same as DATA terminal
10	ST	Strobe input terminal. Attenuation level and channel selection data taken from the DATA and CK terminals are latched when this terminal is placed at "H" level. When "H" level signal is not supplied to this terminal, the previous data is maintained.	
16 7 1	VDD GND VSS	(+) power supply terminal. Earthing terminal. (-) power supply terminal.	

AUDIO DIGITAL IC

-453-

# TC9176P, TC9177P

T-77-21

TC9177P

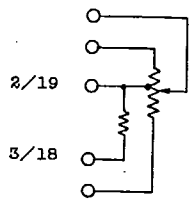
TERMINAL No.	SYMBOL	FUNCTION	REMARKS
2, 3 19, 18	L-Loudness <sub>1,2</sub> R-Loudness <sub>1,2</sub>	Loudness terminal. When the loudness data is input, these terminals is changed to the -20dB tap terminals. Loudness control is possible by the connection of the high and low boost circuits to these terminals.	
4 17	L-OUT <sub>1</sub> R-OUT <sub>1</sub>	10dB/step attenuator output. Signal supplied to IN is attenuated in 8 steps from 0dB to 70dB at 10dB/step.	
5 16	L-IN <sub>1</sub> R-IN <sub>1</sub>	10dB attenuator input.	
6 15	A-GND	Analog ground terminal.	
7 14	L-IN <sub>2</sub> R-IN <sub>2</sub>	2dB attenuator input.	
8 13	L-OUT <sub>2</sub> R-OUT <sub>2</sub>	2dB attenuator output. Signal supplied to IN is attenuated in 5 steps from 0dB to 8dB at 2dB/step.	
11	DATA	Attenuation level and channel selection data input. This data consists of 20 bits and is input by CK signal.	
10	CK	Clock input to take in data from the DATA terminal.	
12	ST	Strobe input terminal. Attenuation level and channel selection data taken from the DATA and CK terminals are latched when this terminal is placed at "H" level. When "H" level signal is not supplied to this terminal, the previous data is maintained.	
20 9 1	VDD GND VSS	(+) power supply terminal. Earthing terminal. (-) power supply terminal.	

**TOSHIBA**



# TC9176P, TC9177P

T-77-21

## DESCRIPTION OF OPERATION

### SETTING OF ATTENUATION

As for the TC9176/77P, optional attenuation level data should be input from the DATA, CK and ST terminals. This data consists of 20 bits.

(The TC9176P has no loudness control and therefore, the 3rd bit must be always at "L" level).

#### TC9176P

L <sup>ch</sup>	R <sup>ch</sup>	'0'	0dB	-2dB	-4dB	-6dB	-8dB	0dB	-10dB	-20dB	-30dB	-40dB	-50dB	-60dB	-70dB	'0'	'0'	'0'	'1'
-----------------	-----------------	-----	-----	------	------	------	------	-----	-------	-------	-------	-------	-------	-------	-------	-----	-----	-----	-----

#### TC9177P Loudness

L <sup>ch</sup>	R <sup>ch</sup>	ON/ OFF	0dB	-2dB	-4dB	-6dB	-8dB	0dB	-10dB	-20dB	-30dB	-40dB	-50dB	-60dB	-70dB	'0'	'0'	'0'	'1'
-----------------	-----------------	------------	-----	------	------	------	------	-----	-------	-------	-------	-------	-------	-------	-------	-----	-----	-----	-----

#### CK

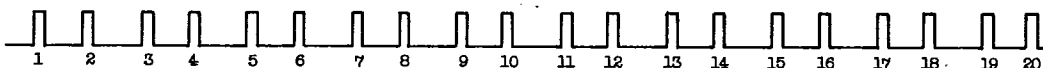

For example, input of data (11001000001000000001) sets attenuation level of -22dB. 1st and 2nd bit of the data are for L<sup>ch</sup> and R<sup>ch</sup> selection.

3rd bit is a loudness control ON/OFF bit for the TC9177P only and the loudness control is ON at "1" and OFF at "0". In case of the TC9176P, it is always "0". 4th~8th bits are for setting attenuation at 2dB/step and 9th~16th bits are for setting attenuation at 10dB/step.

17th~20th bits are chip select bits and both the TC9176P and TC9177P are selected only by (0001) and is never operated by other than (0001).

The infinite attenuation level is set by data of -78dB. Therefore, one step up from the infinity becomes -76dB. Every change to data that has been taken in is synchronized with rise edge of ST signal.

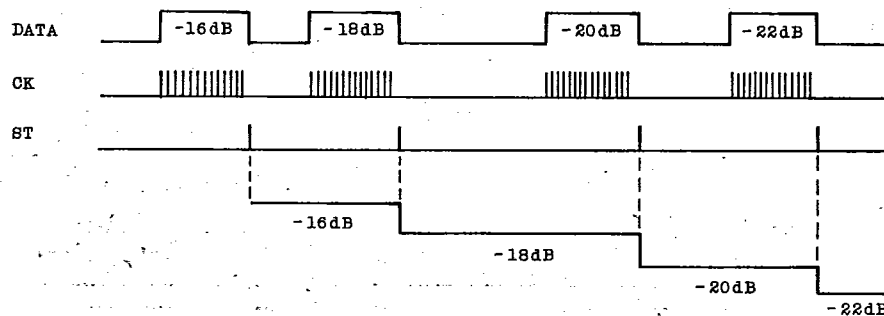

AUDIO DIGITAL IC

# TC9176P, TC9177P

T-77-21

## DATA, CK, ST INPUTS

The TC9176/77P is generally operated by (+) and (-) power supplies. Owing to the built-in level shifter, the DATA, CK and ST terminals are operated by (+) power supply only. The input inverter for these 3 terminals have low input threshold voltage and therefore, these terminals operate at 5V logic level.

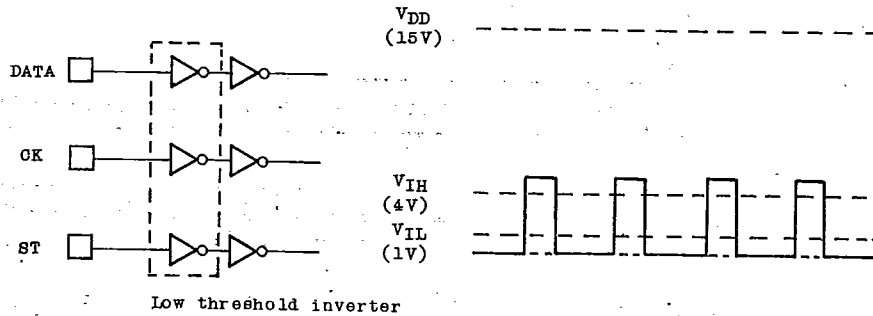

Input DATA, CK and ST at the following timings:

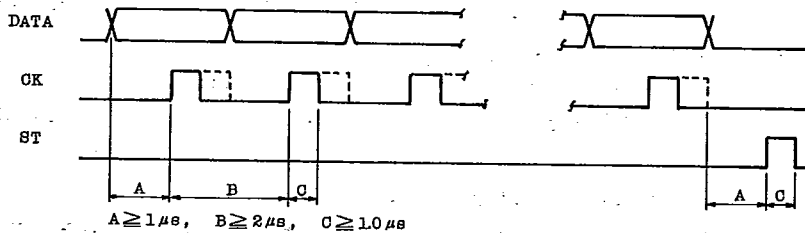

## POWER SUPPLY

Though the TC9176P/77P is generally operated with two power supplies, use of a single power supply is possible. In this case, however, as operating voltage is decided by voltage between  $V_{DD}$  and GND, it will become half of that of two power sources.

### o TWO POWER SUPPLY

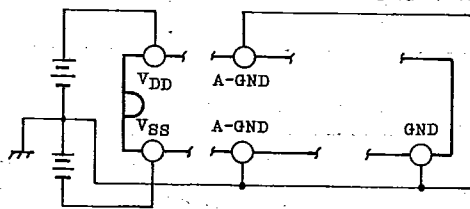

### o ONE POWER SUPPLY

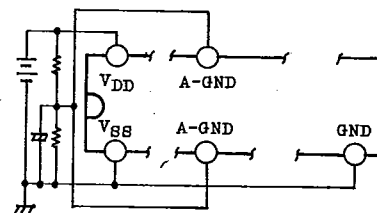

**TOSHIBA**

# TC9176P, TC9177P

## ATTENUATOR

T-77-21

The attenuator consists of diffusion resistor arrays and analog switches.  
Attenuator 1 attenuator 0~70dB at 10dB/step, while Attenuator 2 attenuator 0~8dB at 2dB/step, total 0~76dB at 2dB/step is available.

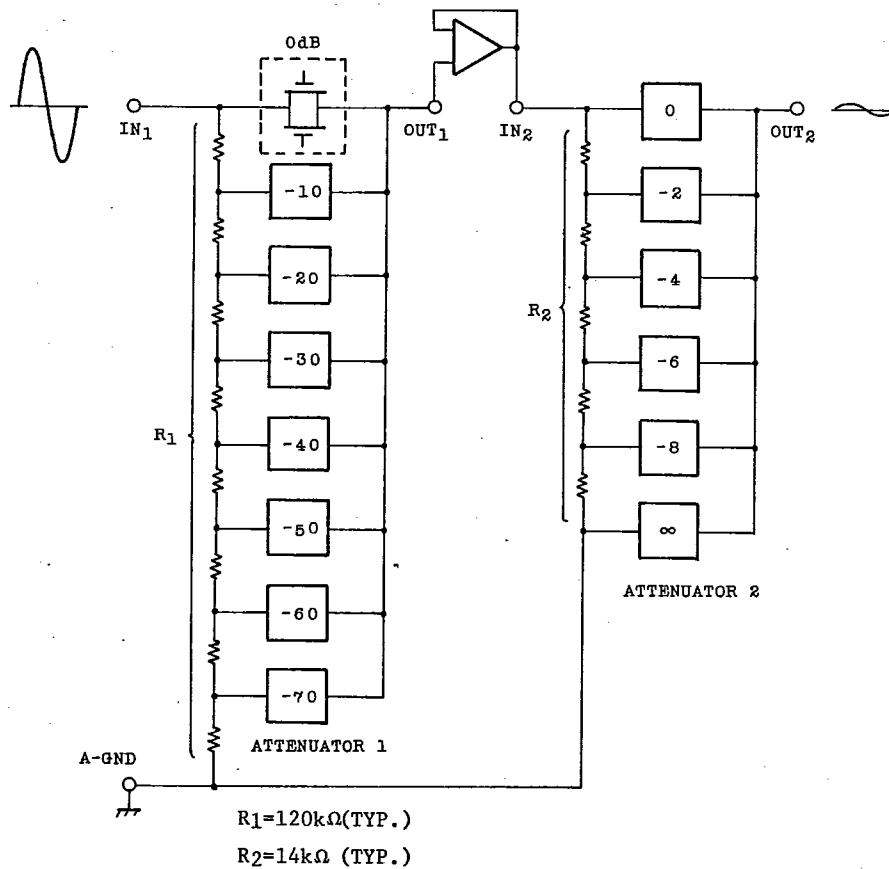

If there is the possibility for input of excessive voltage, insert protective diodes as illustrated below.

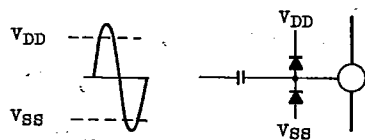

AUDIO DIGITAL IC

# TC9176P, TC9177P

T-77-21

## LOUDNESS FUNCTION (TC9177P)

The TC9177P is provided with the loudness taps.

### LOUDNESS ON

When 3rd bit of data is set to "1", the loudness switch LS<sub>1</sub> is turned ON and LS<sub>2</sub> is turned OFF, outputting -20 dB attenuation level to Loudness-1 and Loudness-2 terminals. When a high/low-pass boost circuit is added externally to Loudness-1 and Loudness-2 terminals, it becomes possible to control loudness to -20dB or below.

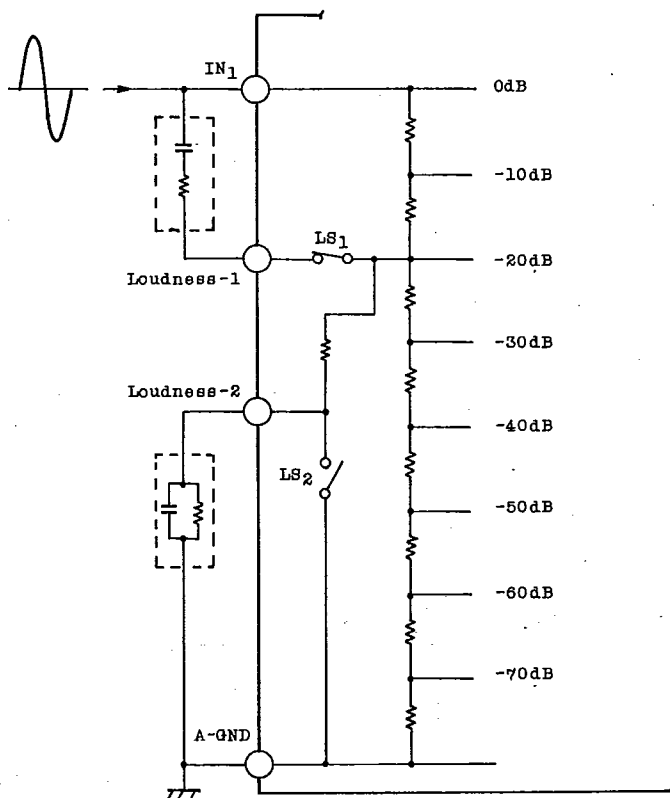

### LOUDNESS OFF

When 3rd bit of data is set to "0", the loudness switch LS<sub>1</sub> is turned OFF and LS<sub>2</sub> is turned ON. The external high/low-pass boost circuit does not operate and the loudness is thus OFF.

**TOSHIBA**

# TC9176P, TC9177P

T-77-21

EXAMPLE OF TC9176P APPLICATION CIRCUIT

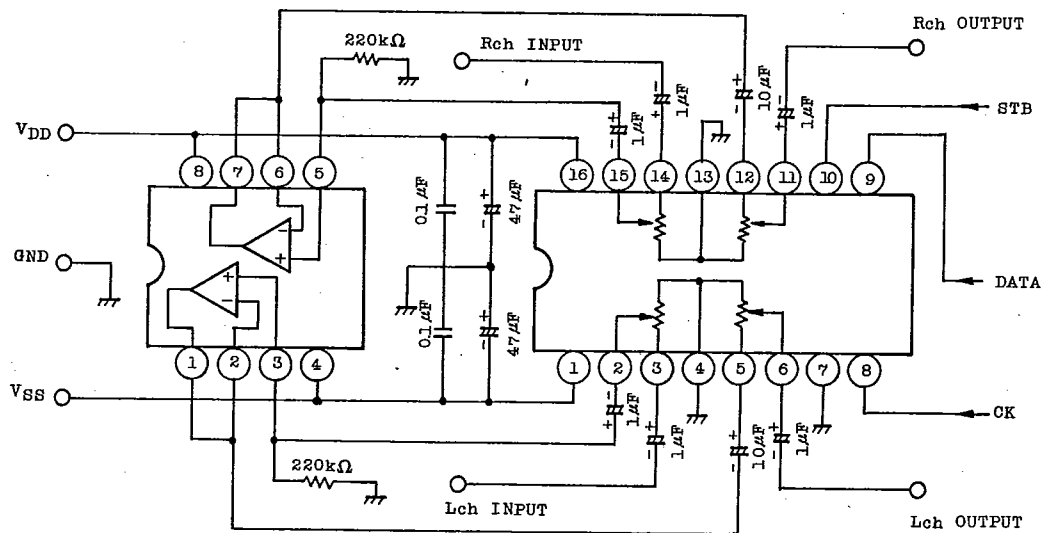

OP AMP: TA75558P, TA7559P or equivalent

AUDIO DIGITAL IC

